

#10
SHARING
ALSTOM GRID
INNOVATION
& PRACTICES

THINKGRID

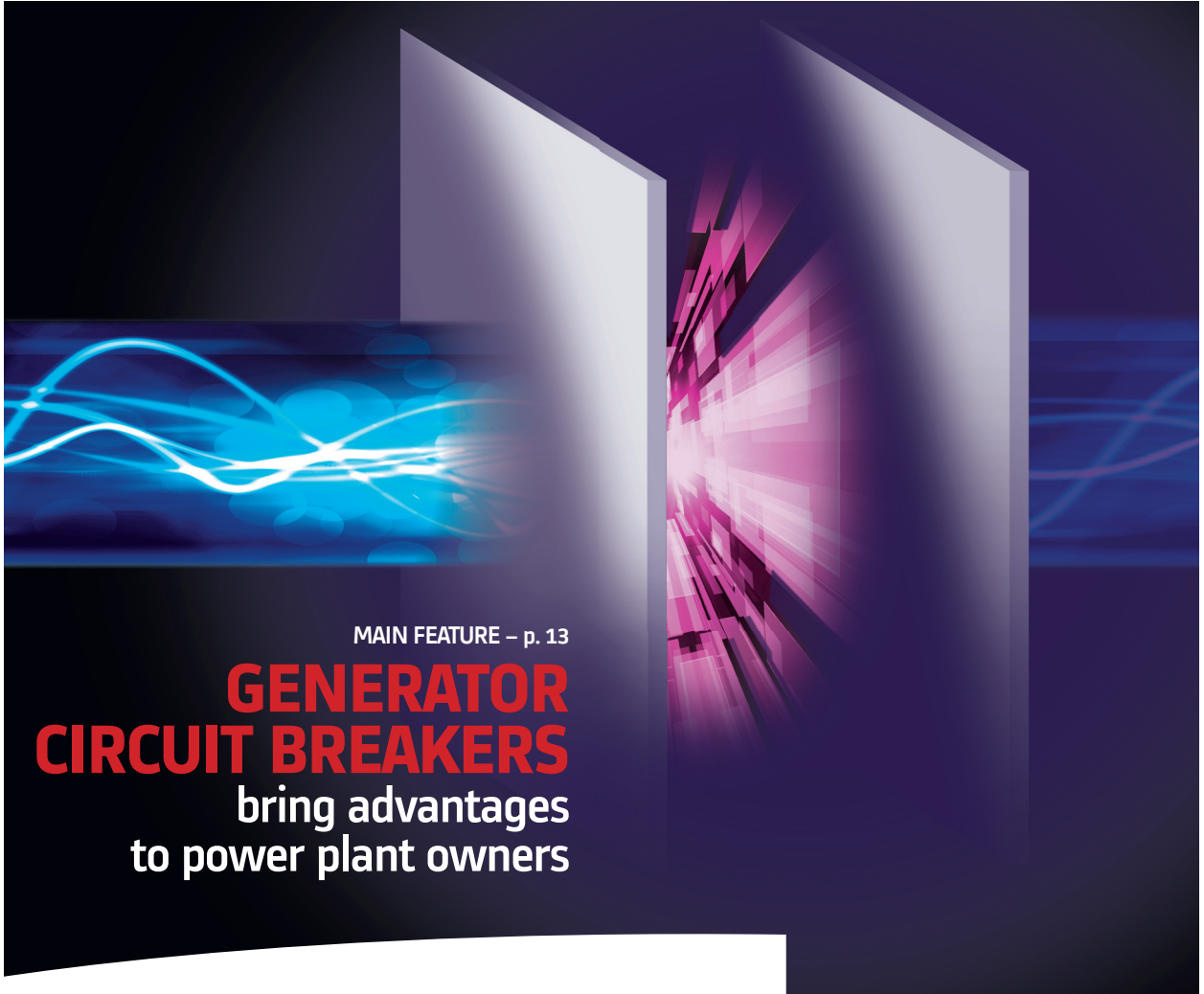

MAIN FEATURE – p. 13

GENERATOR CIRCUIT BREAKERS bring advantages to power plant owners

THINK GRID #10 – SUMMER 2012

We are Shaping the future

ALSTOM

Contents

#10 Summer 2012



08 Interview with ▲
Gareth Evans

06
SuperGrid project
in France ▶



Dr Richard
Charnah,
Publisher



34 Smart products
& services
Transmitting the benefits
of automation and
protection technologies



12

Respecting ▲
the environment
Generator circuit
breakers bring
advantages to power
plant owners

THINKGRID

SHARING ALSTOM GRID INNOVATION & PRACTICES – Published by Alstom Grid –

51 esplanade du Général de Gaulle - 92907 La Défense Cedex – France. www.alstom.com/grid – Print run: 15,000 copies (Chinese, English, French, German, Spanish) – Publisher: Richard Charnah – Editor in chief: Véronique Chauvot – Editorial assistant: Marie-Amélie Norel – Editorial board: Stéphane Lelaidier, Richard Charnah, Walter Dussaucy, Emmanuelle Helleux, Peter Kirchesch – Concept and Design: BythewayCreacom – 19 rue Gallée, 75116 Paris – France – Tel.: +33 (0)1 53 57 60 60 – www.bythewaycreacom.net – Editorial executive: Henry Lewis Blount – Publication manager: Valérie Barral – Contributors: Henry Lewis Blount, Ken Kincaid, Patrick Love, Louis-Antoine Mallen, Manuel Relvas, Gordon Smith – Copy editor: Ginny Hill – Art director: Didier Trayaud – Graphic designer: Cloé Cheucle – Computer graphics artist: Studio V2 – Photo credits: Alstom, Shutterstock, Thinkstock, Creativeworks, Keppel Energy, Harald Wemper – Printing: HandiPrint. ISSN: 2102-017 – A special thanks to the companies that kindly provided us with their illustrations.



23 Innovation & performance

Measuring partial discharge in GIS



Electricity Lore ▲
The history of gas-insulated substations

46

5 FOREWORD

By Stéphan Lelaidier:
R&D Vice-President,
Alstom Grid

6 PANORAMA

SuperGrid project in France

8 INTERVIEW WITH...

Gareth Evans, Head of Profession
Engineering, Ofgem

11 MAIN FEATURE

Pushing the frontiers
of electricity technology

12 Chapter I

Respecting the environment
Generator circuit breakers bring
advantages to power plant owners

23 Chapter II

Innovation & performance
Measuring partial discharge in GIS

34 Chapter III

Smart products & services
Transmitting the benefits
of automation and
protection technologies

44 CROSS-PERSPECTIVES

Consumption management
as part of grid management

46 ELECTRICITY LORE

The history of gas-insulated
substations

50 FURTHER READING

Books, newspapers, etc.

51 DATES FOR YOUR DIARY

Don't miss...



FOREWORD

By **Stéphane Lelaidier**: R&D Vice-President, Alstom Grid

Reliability and sustainability are constant concerns of power utilities and recurrent themes of this issue of *Think Grid*.

The introduction of new equipment, and especially new technologies, can be a source of uncertainty for an operator but this potential barrier can be addressed by introducing monitoring systems or even self-monitoring equipment. You will be able to read about some real cases that illustrate these ideas concerning generator circuit breakers, transformers and gas-insulated substations.

Realistic testing regimes, and the test centres and expertise on which they rely, can also help the process, and this is illustrated with reference to power electronic modules.

Much in a functional electric grid depends on the system aspects. Clearly, this requires that the various pieces of hardware that constitute the system work together seamlessly and that they are monitored and directed in a coherent way. This applies particularly in the integration of renewable energy sources and, whether as part of a regional scheme or in a microgrid, management is key to making the most of the resource. Similar considerations apply regarding reactive power management. Both of these areas are discussed in this issue.

A grid is a technological entity, but its functioning is constrained and facilitated by a wider table of ingredients. Regulation and grid codes, for instance, also play their part. This is most obvious in terms of supply quality, but you can also discover something about their role in sustainability and, yes, even the introduction of new technologies.

Enjoy your reading.

Assuring power supply





Bruno Luscan
Technology Programme Director.

SuperGrid project in France

The French government is setting up a series of "Excellence Centres" in various fields of research to promote the development of a carbon-neutral economy in France. The aim is to emphasise R&D in energy technologies that will reduce carbon emissions. The projects bring together major French players in the industry, large enterprises and SMEs with expertise in energy-related domains and digital technology, as well as leading research and academic centres. To date, nine such Excellence Centres have been launched in energy-related fields; they will be financed by a combination of public and private investment.

Alstom will contribute to one of these major research projects, named SuperGrid, an electricity transmission multi-terminal grid capable of transporting several gigawatts over thousands of kilometres, giving pride of place to ultra high voltage DC (up to 1 million volts). Research will be focused on several programmes such as new protection technologies, power conversion based on high power semiconductor technologies, submarine power cables and dynamic energy storage technologies. These programmes will manage the intermittent renewable energy flow and ensure network security and stability.

The SuperGrid project, based at Alstom Grid's Villeurbanne site, is planned to become operational in 2013. The ambition is to support research and development into products and solutions for implementation by the industry during the next five years, plus new technologies that will be used for industrial applications within 10 years.

GERMANY

Floating, self-installing offshore substation

Alstom Grid has been awarded a turnkey contract to deliver its floating, self-installing offshore substation to connect the MEG 1 wind farm to the German Grid. MEG 1 will be located 45 km north of the island of Borkum in the German North Sea. Planned to be operational by end 2014, it will consist of 80 5 MW wind turbines and feed 400 MW into the public grid, saving close to 1.5 million tonnes of CO₂ emissions annually.

INDIA

Circuit breakers

The Power Grid Corporation of India has awarded Alstom Grid the contract to deliver 64 circuit breakers to a number of 765 kV substations spread throughout India. Alstom Grid will supply everything from design and engineering to erection and commissioning of all the extra high voltage circuit breakers which will be manufactured locally.

KUWAIT

Smart grid solution

The Kuwait Ministry of Electricity and Water is modernising its grid operations and enhancing its network asset management. Alstom Grid is to upgrade the Kuwait Town control centre's energy management system and to install a new integrated distribution and asset management solution. This solution is based on Alstom Grid's **e-terra** platform and **e-terra** distribution to create a single system for managing the control centre's medium and high voltage operations.

SWEDEN

HVDC MaxSine™ – a European first

The Swedish utility Svenska Kraftnät has contracted Alstom Grid to supply the HVDC MaxSine™ technology for its South-West Link project. This will be the first European installation of Alstom Grid's voltage source converter HVDC system. The 1,440 MW South-West Link, the biggest investment in Sweden's electricity infrastructure in 30 years, will connect central Sweden to the south. This Alstom Grid HVDC solution will boost reliability and raise transmission capacity.

TAJIKISTAN

500 kV GIS

Alstom Grid has won a contract to supply the Tajikistan national utility with 500 kV gas-insulated switchgear for the Nurek hydroelectric power plant (HPP). The plant is the largest hydropower facility in Central Asia and, with a 3 GW generation capacity, produces over 75 percent of Tajikistan's electricity. The Alstom Grid GIS will optimise the flow of energy from the Nurek HPP and help secure future energy supply.

CO₂ EMISSION AND TEMPERATURE RISE

Temperature increase versus CO₂ concentration

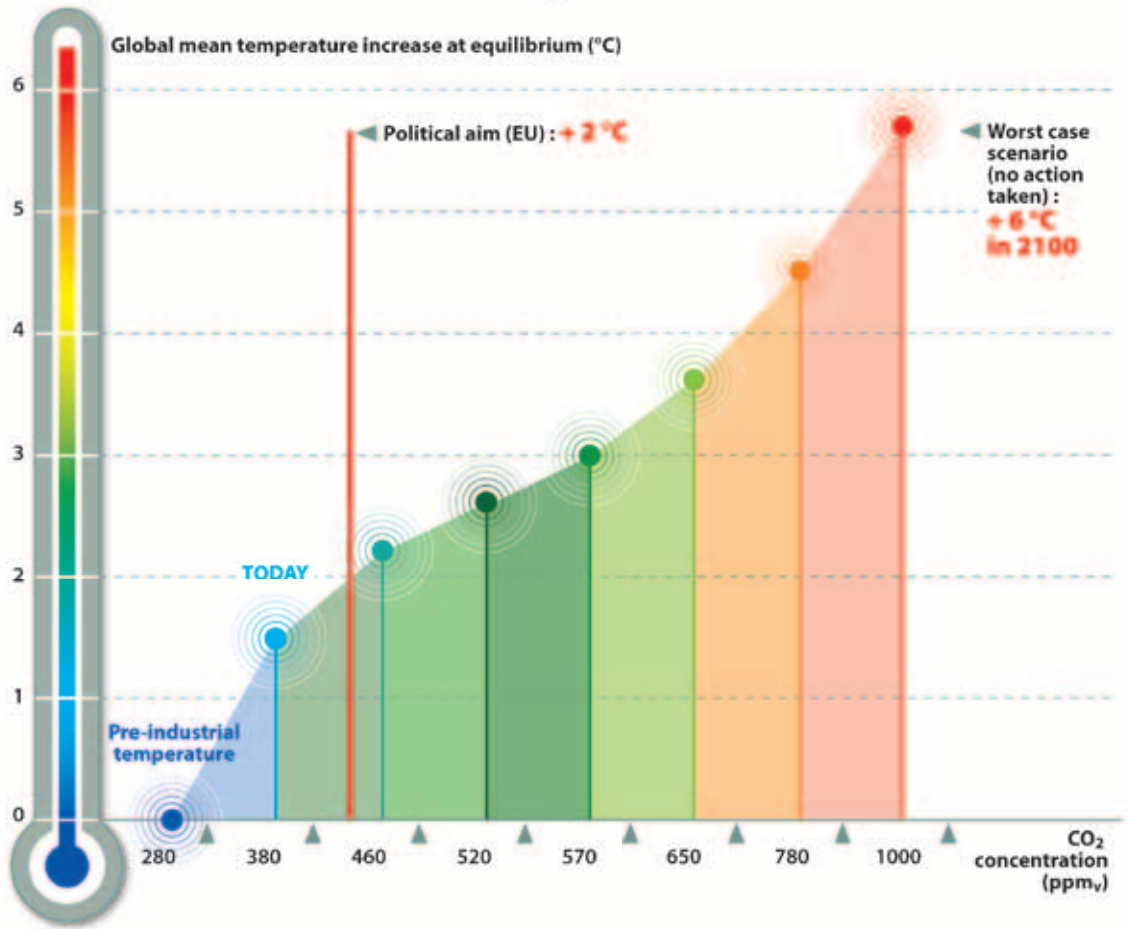

Recent measurements of carbon dioxide (CO₂) show a concentration of 390 ppm_v in the earth's atmosphere. Besides natural sources of CO₂, human-generated release such as burning fossil fuels for heating, power generation and transport play an increasingly dominant role in CO₂ emission. CO₂ is described as a greenhouse gas that significantly contributes to global warming, i.e. to the rising average temperature of the earth's atmosphere. Climate models of the Intergovernmental

Panel on Climate Change (IPCC) indicate a strong relationship between CO₂ concentration and that temperature rise, as shown in the graph. An increase in global temperature will cause sea levels to rise. Depending on the model, the estimated value can be up to several metres. Such a rise, in combination with other climate effects, would have dramatic consequences on our ecosystem. The goal should be to limit future global warming to below 2°C relative to the pre-industrial level, but this requires

deep cuts in greenhouse gas emissions. Better energy efficiency and renewable energy are key to reducing CO₂. Improved energy efficiency reduces the amount of energy required for the same services. For electrical networks, this implies more intelligence to optimise consumption (Smart Grids) and reduce losses, more network connections to use spinning reserves in different networks, etc. Alstom Grid has over 130 years' experience in solving such network issues.

🏠🏠 The energy mix will change dramatically. 🏠🏠



Gareth Evans

Head of Profession Engineering, Ofgem

Mr Evans explains the role of the energy regulator.

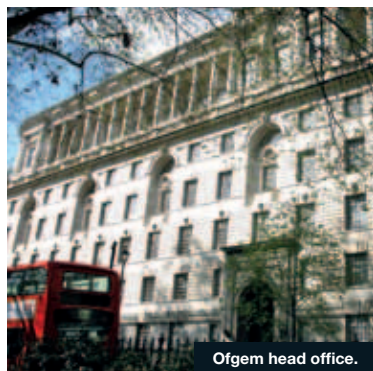

Ofgem head office.



London, ancient and modern.



Shopping in London.

As a leading technical figure at the UK energy regulator, please describe the mission of Ofgem.

Gareth Evans: Ofgem's primary role is to protect the interests of existing and future gas and electricity customers. Ofgem is an economic rather than a technical regulator. However, because the industries we regulate have engineering at their core, it is essential that we have the expertise to engage with the companies and other stakeholders on a technical as well as an economic level.

Ofgem is taking a particularly proactive approach in relation to the encouragement of innovation and efficiency in the network companies, both through our new price control, RIIO (Revenue = Incentives + Innovation + Outputs), and in our specific funding mechanisms such as the Low Carbon Networks Fund. The RIIO acronym captures the idea that "Revenue" should be linked to "Outputs", which in turn are driven by "Incentives" and "Innovation".

In what way is Ofgem concerned with the technologies of the equipment deployed on the electricity grid?

G.E.: As an economic regulator, we are technologically agnostic. The RIIO regulatory framework we have adopted focuses on outputs, but to make sure the companies we regulate deliver their services in a cost-efficient way, we have to be aware of the opportunities that new technologies can deliver. The smart grids debate is a good example of this. We could adopt a completely "hands-off" approach and leave the companies to develop their own strategies towards new network technologies. However, we have taken the view that this is such an important issue that we need to provide leadership. We have done this by establishing the Smart Grids Forum, which brings all interested stakeholders together. Our goal is to establish a consensus as to how our electricity

networks might best evolve to meet the new challenges. These relate in particular to increased demand from heating and transport, the widespread connection of distributed renewable generation and the active control of demand to help balance the total system.

The energy mix is changing. How can regulators help with the physical/technical aspects of these changes?

G.E.: The energy mix will change dramatically, both on the supply side and the demand side, driven by the need to decarbonise the energy supply chain. The challenge for regulators is primarily to ensure that these changes take place such that environmental targets are met as cost-efficiently as possible while maintaining or improving the security of energy supply. Governments play a pivotal role →→



→ here. In Great Britain, the government encourages specific outcomes in terms of the energy mix. For example, there are incentives to encourage renewable generation on the supply side and incentives for electric vehicles on the demand side. The vital link between the two is the electricity network. This must be a cost efficient, secure facilitator of low carbon generation and demand-side technologies. As Ofgem regulates the network companies, we have a vital role to play.

In several traditional industrial economies, major elements of the grid infrastructure are ready for renewal and/or restructuring. How are regulators involved in this process?

G.E.: A key element of our price control settlements for the network companies is to agree the rate of renewal necessary to maintain network safety, integrity and reliability. We have encouraged better

approaches to network asset management so that the process of renewal is cost efficient. However, more importantly, this process of renewal presents a great opportunity to update the networks to meet the new challenges that we foresee.

How important is the “smart grid” and what is the regulator’s involvement in its development?

G.E.: Smart grids are not important in themselves. It is what they can deliver that is important. Ofgem believes that the use of new network technologies will deliver benefits to customers. We have established the Smart Grids Forum to bring key stakeholders together to help us and the network companies develop a strategy for the deployment of these technologies. The forum has already done valuable work and published reports describing potential smart grid solutions and a framework to evaluate their benefits compared with conventional solutions. This work is being taken up by the

🏠 The use of new network technologies will deliver benefits to customers. 🏠

network companies. We believe that we need to take a leadership role in taking smart grids forward while letting the network companies ultimately decide what is right for their businesses.

There are organisations that bring together regulators from different countries. What are their main roles or actions?

G.E.: We play a very active role in the Council of European Energy Regulators (CEER), and I am personally involved in CEER’s work on smart grids. A CEER position paper on smart grids provided very useful input to the European Commission’s communication, which was published in April last year. The Commission has now relaunched its smart grids task force and CEER will play an active role.

What targets does a regulator typically set for utilities (service quality, outages, environmental, etc.)?

G.E.: The most commonly reported service quality parameters are customer interruptions and customer minutes lost. Standards of performance are commonplace in many countries, though there are variations in what is covered, eligibility and compensation levels. Losses are also reported by many states, and CEER has published benchmarking reports to compare the performance of different countries. In Great Britain, we have put in place additional measures, including network outputs for both asset health and asset loading, a mechanism for worst-served customers and a broad measure of customer satisfaction. We have environmental output measures such as business carbon footprint and reporting on oil and SF₆ leakage. We also have a suite of connections-specific standards of performance, plus a connections competition test against which all licensees must be assessed. ■

Pushing the frontiers of electricity technology



12 Chapter I
Respecting
the environment

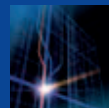

23 Chapter II
Innovation
and performance



34 Chapter III
Smart products
and services



Respecting the environment

Generator circuit breakers are crucial devices in a power plant. They play a key role in the protection of the transformer and the generator in case of fault and in normal operation they connect and disconnect the generator to and from the grid.

Controlled overloading of transformers demands real-time monitoring. Alstom Grid's MS 3000 monitors, analyses and diagnoses in real time, correlating all the data into a single system.

Alstom has developed the world's biggest offshore wind turbine, the Haliade 150, featuring a direct-drive, permanent-magnet generator. ■



Generator circuit breakers bring advantages to power plant owners

Besides playing a major role in power plant protection, Generator Circuit Breakers (GCB) offer more flexibility for plant operation and enable the implementation of efficient solutions to reduce investment cost. Maintenance, energy efficiency and carbon footprint are now also enhanced thanks to GCB architecture optimisation.

Generator Circuit Breakers (GCB) are power plant devices located between the generator (which produces electricity at a voltage of around 15-25 kV) and the step-up transformer (which increases this voltage up to the grid transmission voltage – 200 kV to 800 kV). They play a key role in the protection of the transformer and the generator in case of fault (short circuit on the power transmission system), and their major function in normal operation is to connect and disconnect the generator to and from the grid with high

availability and reliability. For decades, GCBs have existed for generator ratings ranging from 50 MVA to 1,400 MVA. More than 7,000 units are in service today throughout the world, and they have improved the overall life cycle cost of power plants through efficient protection of generators and transformers and simplifying synchronisation to the grid.

GCB: an insurance policy

What concerns a power producer is to generate and deliver energy. With a generator

circuit breaker, a producer can gain flexibility by making the plant's strategic connections safer; it can also reduce the effects of a generator or transformer failure by reducing its duration. "Equipment today has reached a very low failure rate, but a rare phenomenon can still have disastrous effects," says Jean-Marc Willième, Senior Expert at Alstom Grid's High Voltage Switchgear Research Centre in France. "GCBs are something of an insurance policy: as long as everything goes well, the →→



GENERATOR CIRCUIT BREAKER

The Alstom FKG1N GCB designed for power plants of 150 to 300 MW.

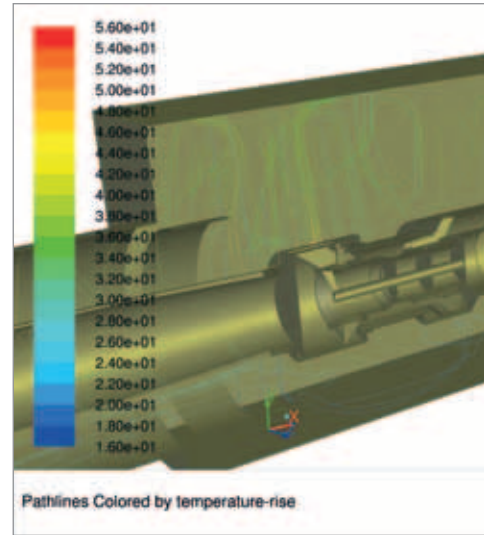

Pathlines Colored by temperature-rise

→→ GCB could be seen as an unnecessary cost, but when things go wrong, what a relief to have it there!” A financial study, based on life cycle cost, has compared the situation of power plants with and without a generator circuit breaker. Analysing the risk of fault, which includes, on the one hand, the cost of not producing, and on the other hand, the cost of a generator circuit breaker solution, it validated the installation of generator circuit breakers. “A typical example, based on a 400 MW power plant, demonstrates that the GCB solution is cost effective if, during 20 years, the presence of the GCB has avoided less than 14 hours of outage,” explains Willième. Moreover, if some cost reductions in GCB schemes are taken into account, such as eliminating HV circuit breakers and HV/MV transformers and replacing them by a GCB and an MV/MV transformer to feed auxiliaries (see sidebar 2), “savings could be identified from the very beginning of the project”.

Alstom’s GCBs continuously enhanced and upgraded

In the world of circuit breakers, breaking capability is a very important feature to have adequately specified in case of a major fault in a power plant. This kind of failure is extremely rare, but has very heavy consequences, so the design of the interrupting

Generator Circuit Breakers are something of an insurance policy.

chamber – the heart of the generator circuit breaker – is a crucial factor. Alstom Grid has continually developed and improved this mechanism. Thanks to the thermally assisted puffer-type technology, it is pos-

sible to interrupt short-circuit currents of at least 160 kA with a spring-operating mechanism. Some years ago, a CIGRE study on high voltage circuit breaker failures and defects in service revealed that the availability of the circuit breakers depends mainly on the reliability of the operating mechanism, and that the most reliable mechanism, by far, is the full spring mechanism. For its latest generation of GCBs, Alstom Grid has optimised and enhanced its spring-operating mechanism to make it simpler, save energy and reduce stresses and impacts during operation. As a result, the improvement in reliability and availability of the generator circuit breakers using spring mechanisms is now accessible for power plants up to 1,400 MVA.

GCBs originally used air blast technology for electric arc extinction. Air blast, still applied for the highest ratings of breakers⁽¹⁾, was progressively replaced in the mid-80s by sulphur hexafluoride (SF₆) technology,

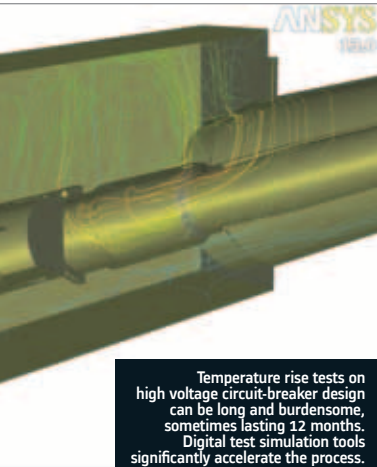

Temperature rise tests on high voltage circuit-breaker design can be long and burdensome, sometimes lasting 12 months. Digital test simulation tools significantly accelerate the process.

Mar 09, 2012
ANSYS FLUENT 13.0 (3d, dp, pbns, ske)

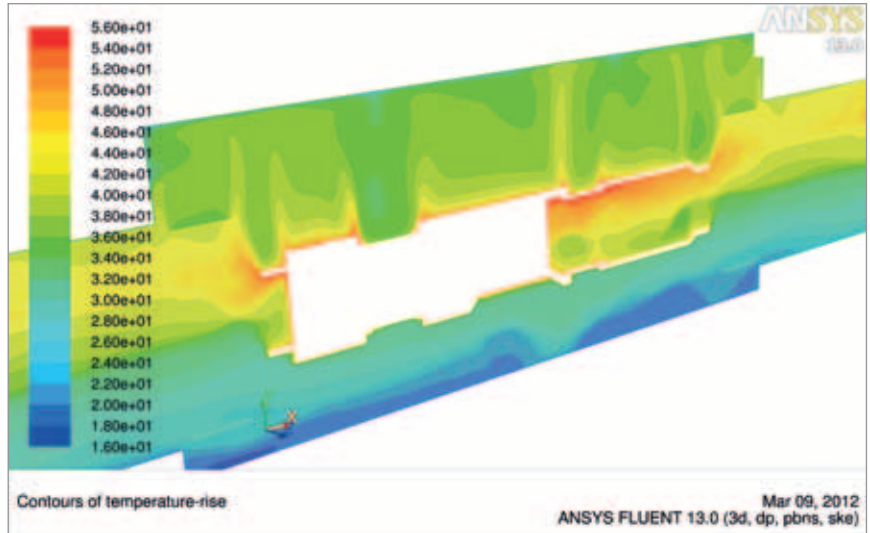

Contours of temperature-rise

Mar 09, 2012
ANSYS FLUENT 13.0 (3d, dp, pbns, ske)

where the SF₆ is used instead of compressed air. Therefore, SF₆ breakers can be self contained in a sealed chamber and do not need a centralised compressed air supply as required by air blast breakers. One of the resulting advantages is that the GCB size is considerably reduced. However, the interrupting chamber architecture remains roughly the same, with main contacts used for carrying any currents while arcing contacts are plugged on by commuting the current to them from the main contact. This allows arcing to take place between arcing contacts until the arc is completely extinguished.

Keeping losses as low as possible

To reduce life cycle cost, the design of a GCB focuses on the status of the arcing contacts, which suffer heavy wear when operating and can be considered as strategic for the breaker. However, "another important feature of the generator circuit breaker is its

🔧🔧 The most reliable mechanism, by far, is the full spring mechanism. 🏠

capability in terms of rated current," says Willième. Although this is around one-tenth of the breaking capability, manufacturers have to carefully design their breaker around this issue. "As the main current specification is related to a function that is active almost 100 percent of the operational lifetime of the generator circuit breaker, what is needed is a current-carrying capability with losses as low as possible." This concern is reinforced by the fact that circuit breakers are traditionally associated in series with line disconnectors, whose role is to provide personnel with visible safety during maintenance. Unfortunately, disconnectors also have permanent disadvantages: they are a

source of loss during energy production phases; they also increase the occurrence rate of minor risks such as mechanical failure, and major risks such as thermal runaway of contacts; consequently, they need more maintenance.

The sizing of both circuit breaker and disconnector for loss reduction requires the full attention of the designer. This is reinforced by the fact that the environmental footprint of electrical equipment is mainly related to the energy dissipated during the total GCB life operation, rather than to the energy or material consumed during manufacturing process. "The most efficient way to avoid energy waste in this equipment is to reduce energy sources by design," Willième points out.

A breakthrough in efficiency and environmental friendliness

The classical SF₆ circuit-breaker layout is not 100 percent effective regarding →→

FLEVO POWER STATION, NETHERLANDS

This station is among the best performing power plants in the world with low NO_x, SO_x and CO₂ emissions. It features a high operational flexibility, since it can run at base load and part loads as well as in two-shift operation mode. It is designed around two GT26 combined cycle modules rated at 435 MW each for a gross output of 870 MW at 59% efficiency.



→→ loss reduction. As SF₆ pressurised volume is linked to contact sizing, designers have to make compromises between Joule loss reduction and minimising SF₆ volume. Another drawback is that the main contacts are in the same environment as the arcing contacts and consequently are subjected to the hot, current-breaking gas flow as well as corrosive SF₆ by-products. “An innovative architecture – the FKGA2 – avoids these compromises by allowing the main contacts to be completely isolated from the heated current-breaking SF₆ gases, contaminated particles and the associated by-products within the interrupter chamber,” explains Williëme. Their lifetime is therefore independent of the breaking events experienced by the interrupter chamber. The integration of the circuit-breaker main contacts and disconnecter function into a single piece of equipment is particularly effective in decreasing losses: the electrical resistance is far less compared to the classical solution (circuit breaker and

disconnecter in line), so heat dissipation is reduced throughout the equipment lifetime. Additional benefits include a reduction of the equipment’s total phase length; hence less material is used, and manufacturing processes are reduced, resulting in less impact on the environment. The combination of these different factors, including reduction of SF₆ volume, leads to a significant decrease in the equipment’s environmental footprint.

Easier inspection for the main contacts

Beyond environmental considerations, power plant owners are concerned by the reliability and availability ratio of their plant and by the immediate negative consequences of a failure. For this reason, it is crucial to detect the predictive signs of future failure at the earliest possible stage. As the main contacts are a major contributor for the transmission of the energy produced by the power plant, it is a big advantage to

MORE



Gwenaël Marquézín

USE OF MULTI-PHYSICS OPTIMISATION FOR DESIGNING CIRCUIT BREAKERS

The development of digital simulation tools and the exponential increase in computer power allow engineers to greatly accelerate the design of industrial applications such as high voltage GCBs. They can pre-evaluate a design on computer models to examine its behaviour for different operating conditions and therefore optimise the product before the first prototype is built and tested. As a result, test duration and cost can be substantially reduced. “Generator circuit breakers are extreme products due to the very high currents imposed by their position on the network,” says Gwenaël Marquézín, HV Switchgear

Expertise Development Manager. “Optimising their design for higher performance and efficiency, making them more robust and compact (such as in the FKG series), leads to increasingly complex problems to solve as design constraints are closer to the limits.” Therefore, “multi-physics simulations are necessary to better understand and evaluate the combination of physical constraints and their effects on the breaker’s behaviour, performance and lifecycle.” Besides the complex simulations of breaking tests, GCB designers rely on the simulation teams to recognise such effects as the electromagnetic forces

generated by the high short-circuit currents, Joule power and related temperature rise due to the high nominal current, seismic response of the equipment, etc. However, beyond theoretical knowledge, these teams “must possess the practical competencies to be able to cast a very critical eye at simulation results, their significance and correlation with test results.” Dielectric, thermal and mechanical phenomena involved in the circuit-breaker design are nowadays relatively well understood; others, like coupled electromagnetic and fluid approaches, are highly complex and require extra care.

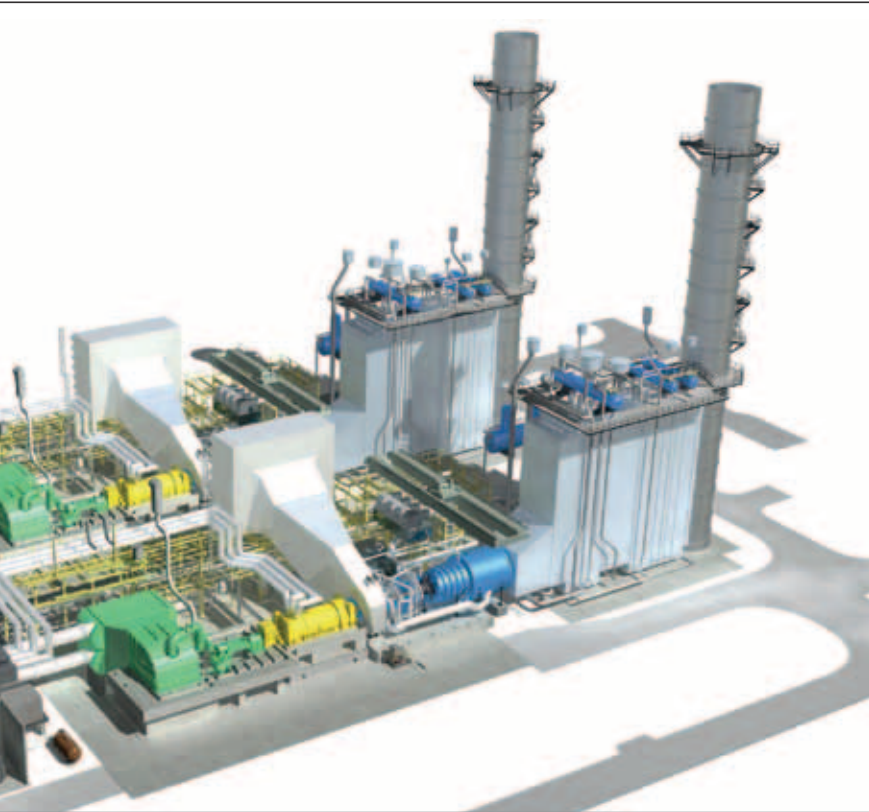

MORE

Henry Doulat

GCB SOLUTIONS – LOWER COST, FLEXIBLE AND MORE PROTECTIVE

There are two major options when designing the electrical single line diagram for a power plant:

- the block diagram scheme: the generator output is directly connected to the Generator Step-Up Transformer (GSUT), and the connection of the unit to the grid is through an HV circuit breaker; this scheme requires a Station Service Transformer (SST) to feed the unit auxiliaries when the generator is not connected to the grid;
- the generator circuit breaker scheme: the HV circuit breaker always remains closed and the unit auxiliaries are permanently fed through the GSUT and the Unit Auxiliary Transformer (UAT).

For the user, the GCB scheme has three main advantages:

- it is a more economical solution, as the GCB's cost is made up for by the savings from avoiding an SST and its associated connection to the HV grid;
- it avoids auxiliary power supply changeovers at unit starting and stopping; for large power plants these changeovers may be complex and induce important transients if the two supplies are not in phase;
- GCB enables fast elimination of faults (80 ms) on the energy transmission system (GSUT, UAT, busbars), and therefore limits the consequences of the fault, whereas with the block diagram scheme, the generator will continue to feed the fault for several seconds until the generator is fully de-excited.

be able to easily observe the main contacts throughout the equipment's lifetime in order to detect any trace of abnormal wear on the contact surface. The value of having accessibility to the main contacts is enhanced by the fact that contact resistance measurement cannot alone be considered as reliable evidence of an increase in temperature. Furthermore, the new joint IEEE-IEC GCB standard draft recommends visual inspection of main contacts as an efficient "verification of the capability of the GCB to carry the rated normal current". Contact inspection consumes a large portion of maintenance time with a classical breaker architecture, where main contacts are hidden in a sealed envelope containing

Heat dissipation is reduced throughout the equipment lifetime.

SF₆ gas under pressure and subjected to hot gas flow; currently it is only possible to inspect the contacts during complete overhaul sessions of several weeks. By segregating the main contacts from the interrupting SF₆ gas, the new FKGA2 provides

simple access from outside the breaker during a short, normally scheduled power plant shutdown. The main contact inspection

is considerably easier than with the conventional GCB architecture and, when necessary, parts replacement is also significantly less burdensome. ■

(1) Alstom Grid's PKG pneumatic-type generator circuit breaker is the biggest circuit breaker in the world, with a rated short-circuit breaking capacity up to 275 kA.

ALSTOM GRID'S MS 3000



Monitoring turns overloading into optimised use

In today's deregulated transmission market, many operators have little choice but to overload their transformers. Continuous real-time monitoring enables them to control overloads without overheating and ageing their transformer insulations.

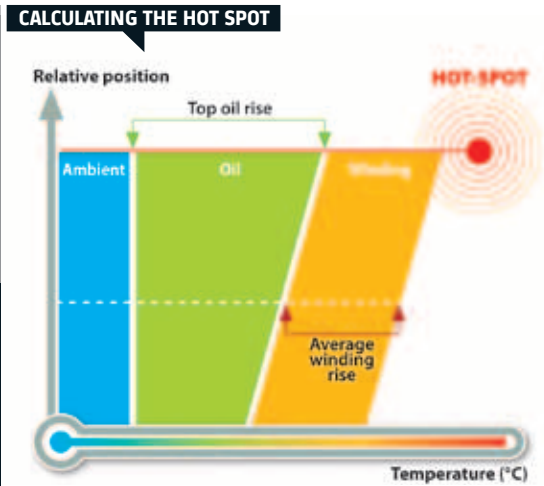
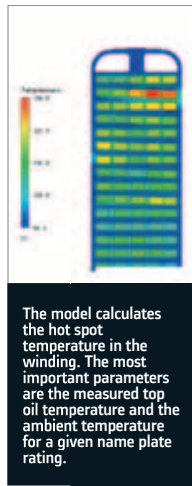

“Overloading” is by definition undesirable. Its excessive heat over time ages transformers’ solid insulation. The paper in the insulation becomes brittle and unable to cope with any of the normal electrical and mechanical wear and tear that is part of the daily grind within a transformer. The ageing process of even thermally upgraded paper, designed to withstand a top-rated temperature of 110°C with normal ageing, doubles for every 7 K rise in temperature. Insulation cannot be repaired. The end of its life spells the end of the life for the transformer.

However, overloading is also necessary and the transformers designed in accordance with international standards can also be overloaded as indicated in loading guides such as the IEC 60076-7. Nevertheless, loads greater than the nameplate rating involve a degree of risk and accelerated ageing, as the IEC loading guide points out. The guide states that long-term overloads age the solid insulation, short-lived overloads impair its dielectric strength, and overloading generally can raise the temperatures

of parts like bushing connections so high that it causes thermal runaway.

Smart grids require overloading

Such risks have grown steadily greater in the operating conditions particularly noticed in open, deregulated power generation and transmission markets. They are becoming

🏠 Loads greater than the nameplate rating involve a degree of risk. 🏠

ever more pronounced with the introduction of renewable energies, particularly wind power, as part of a demand-led smart grid. It can be practically impossible to plan for fast-fluctuating load cycles. Utilities, seeking to get the most out of their assets, turned to controlled overloading, which calls for careful real-time monitoring and condition

diagnosis. “Alstom Grid’s MS 3000 online monitoring system is an interactive monitoring and expert system. It monitors, analyses and diagnoses in real time. And it correlates all the analysed data into a single integrated system – for one or more transformers,” says Bartłomiej Dolata, who manages Design & Engineering Monitoring Systems at Alstom Grid’s Competence Centre in Germany.

Sensors placed in a substation’s transformer or transformers transmit readings to a modular fieldbus system that converts the analogue readings to digital data for storage in a real-time database and a historical database. “The historical database is like a medical record,” says Dolata. “It helps understand how and even why the transformers behave the way they do.” The system’s visualisation software incorporates several modelling algorithms for condition diagnosis and prognosis. “It supports operators by advising what will happen if they don’t take remedial action,” says Dolata, “and recommends what parts or processes to check and what action to take.” →→

→→ The system uses IEC standard 61850 for communication with power systems, which enables reliable and flexible data exchange. “Users can also see what is going on in the meaningful, easy-to-read visualisation software,” says Dolata. “And they can use it to generate reports or get help and advice. Monitoring with MS 3000 is in fact an interactive experience.”

Hot spots a hot topic

What actually limits a transformer’s overload capacity is the temperature of its winding. Although windings undergo tests to show that their temperature does not rise above industry standards, such tests give the average temperature across all the winding’s parts. Its hottest area is known as the “hot spot” and is the real limiting factor. If no fibre optic sensor is installed in the winding, the hot spot cannot be accessed for measurement. And even then measurements yield only the current state of overload. “With modelling you can determine future developments,” explains Dolata. New development of thermal model and pilot projects have been started to calculate the hot spot, which in turn enables it to continuously calculate a transformer’s permissible overload. The implemented thermal model based on principles of IEC standards is ample

for calculating the temperatures of the hot spot and top oil in normal cyclic loading conditions where the load factor does not exceed the IEC’s standard 1.3 at a maximum hot spot of 120°C and 105°C for top oil temperature. Furthermore, under steady state condition, the modelling used calculates the time needed to overload the transformer in short-time emergency loading condition. However, in order to cope with sharp fluctuations in load or heavy emergency overloads, where IEC 60354 or 60076-7 requires transformers to withstand overloads of 1.5 times the rated current for up to 30 minutes at a maximum hot spot temperature up to 160°C, the thermal model has to be improved and advanced. The use of such continuous overload diagnostic models enables dynamic load management. The importance of continuous overload monitoring is thrown into sharp relief by the fact that the hot spot temperature of 120 °C, although permissible by international standards, nevertheless increases ageing by a factor of 12 compared to running at a temperature of, for example, 98 °C for non-upgraded paper insulation. For high-precision

🏠 Its hottest area is known as the hot spot. 🏠

monitoring of continuous overload capacity, the insulation’s moisture content should also be factored into the thermal model. As the transformer heats up, moisture migrates from the paper into the oil. When moisture in the oil exceeds 2 percent, residual water may become trapped in the paper and then escape in the form of water vapour bubbles. These bubbles would go with the oil flow or get trapped in the winding, causing a possible breakdown of the insulation. Furthermore, water content in the oil of 4 percent accelerates ageing by a factor of 20. ■

Life expectation for insulation paper versus hot spot temperature

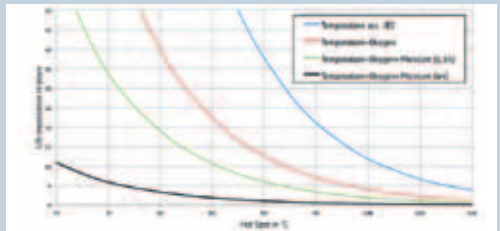

IEC operation cycle loads

	Normal cyclic loading – High load cycles offset by low load cycles	Short-time emergency loading – Unusual heavy loads of durations shorter than transformer’s thermal time constant (t ≤ 30 minutes)
Hot spot temperature	<120°C ->ageing rate up to 12	<160°C (oil bubble temp. 140°C)
Top oil temperature	<105°C	<115°C
Maximum load factor	1.3 (130%)	1.5 (150%)

KEY FACTORS AND FIGURES

The lifetime of its paper insulation determines a transformer’s life expectancy. Temperature is one of the main factors of cellulose chain ageing. The figure above shows the sensitivity to temperature of non-thermally upgraded paper in an oxygen-free environment. Its life expectancy is reduced at even faster rates if oxygen or moisture is present. Overload is the main factor causing

high temperatures. To determine a transformer’s overload capacity its hot spot has to be calculated. The MS 3000 monitoring and

diagnostic system incorporates a thermal model to assess a power transformer’s overload capabilities within the limits set by the IEC.



🌱 Bartłomiej Dolata

THE HALIADE 150-6MW



A new generation of offshore wind turbines

Reliability is one of the most important parameters in the design of offshore wind turbines. But the extreme environmental conditions pose significant challenges.

The first electricity generating wind turbines were invented at the end of the 19th century. They have come a long way since then, in part thanks to the pioneering work of Barcelona-based Ecotécnia, acquired by Alstom in 2007. With solid references in onshore wind turbines, the company has launched into offshore. Its new vanguard product, the Haliade 150-6MW with its 150 metre rotor diameter, the world's biggest offshore wind turbine, is at the cutting edge of wind turbine technology.

"One of our key challenges was to protect the installation against the elements so that it can operate reliably for 20 years or more," says

Daniel Castell, Offshore Wind Platform Director. That required protecting all external surfaces from corrosion due to humidity and salinity. "Many external parts are made of glass fibre to withstand the elements, but all outside-facing components are coated just like a ship," adds Castell. "Also, the inside workings are completely sealed and a filtered and dehumidified air flow is injected inside, creating a slight overpressure that avoids corrosion in the sensitive internal components." Other contributions to reliability enhancement have been facilitated by the failure-mode analysis that has enabled the engineers to calculate the potential failures and the time

between failures. Failure-mode identification is then used as the tool to implement risk mitigation actions in order to fulfil the demanding reliability targets. In addition, the Haliade 150-6MW features remote operation and remote diagnosis, with condition-based maintenance, which means that inspection is carried out without the need to be on site. If necessary, any resetting is also done from the shore, saving cost and time and allowing corrective action to be taken more rapidly.

Designed from scratch

However, the reliability of the Haliade 150-6MW turbine is largely the →→

→→ outcome of a whole series of innovations. "Instead of adapting onshore technology to offshore requirements, the Haliade was completely designed from scratch," Castell stresses. A prime example is the direct-drive permanent magnet generator. Here, to improve the performance of the large structure, the magnets have been located in the rotor and the windings in the stator only. This makes the generator simpler, lighter, more robust and more reliable, compared to traditional solutions with windings in both the stator and the rotor. "This solution is new to offshore wind turbines," adds Castell. The direct drive approach is also an innovative wind turbine solution. In conventional wind turbine designs, the generator speed is high and a gearbox is used to step up the shaft speed. "But a gearbox has lots of components such as bearings and gears that make the installation heavier, less reliable and more expensive to service," Castell points out. In contrast, with direct drive the generator is directly attached to the turbine rotor. This means that the generator's rotational speed is the same as the blade's rotational speed. It also means that the generator itself is much larger, but it is robust enough to withstand the forces exerted on it and still make the

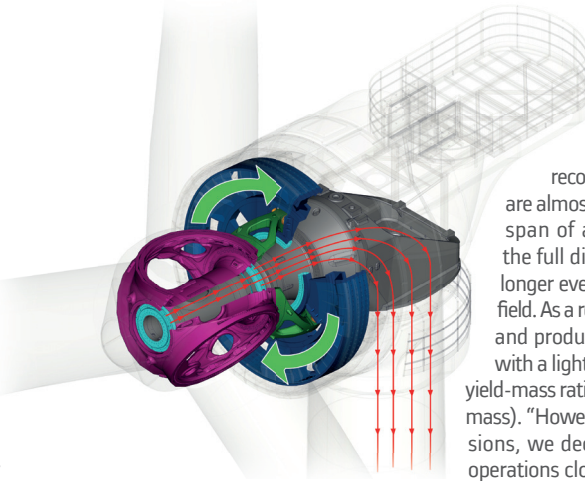

a wind turbine (the previous record was 12 metres less) and are almost as long as the total wing-span of an Airbus A380. In fact, the full diameter, at 150 metres, is longer even than a standard football field. As a result, it captures more wind and produces more energy per turn with a lighter solution, optimising the yield-mass ratio (MWh per tonne of head mass). "However, with such huge dimensions, we decided to locate assembly operations close to the shore – as close as possible to the final location – to minimise transport issues."

THE ALSTOM PURE TORQUE® FEATURE

overall installation lighter. A key feature of the direct drive permanent magnet generator is its failure tolerance, thanks to having three independent generation lines; failure in one line does not affect the others, and operation can continue at de-rated output. Thanks to the larger rotor diameter, it is estimated that the Haliade 150-6MW will show an annual energy production rate 15 percent higher than the current generation of large turbines. The blades themselves are unique. At 73.5 metres in length, these blades are the largest ever manufactured for

Commercial potential

The first Haliade 150-6MW turbine has been installed – onshore – at Le Carnet near the Saint-Nazaire manufacturing location in the west of France. It has successfully completed assembly testing and is currently in commissioning. A second turbine will be installed offshore in a wind farm off the Belgian coast by the end of 2012 to undergo further tests under real-life conditions. Alstom recently won a major contract from the French government to supply its Haliade wind turbines for three offshore wind farms, one off Saint-Nazaire and two off the Normandy coast in the north of France. Production of pre-series will start in 2013, and the commercial production in 2014. Operation is programmed to start up in 2016. ■

It captures more wind and produces more energy per turn with a lighter solution.



ROBUST, RELIABLE AND HIGH-PERFORMANCE – PURE TORQUE®

The robustness and performance of the Haliade 150-6MW offshore wind turbine is due to a great extent to the innovative electromechanical layout that combines Alstom's rotor support technology with a direct drive permanent magnet generator, resulting in the superior reliability of the turbine's single-flange drive train structure that produces and transmits the electricity.

The fluctuating forces and changing directions of the wind in offshore installations could be detrimental to the drive train. The ALSTOM PURE TORQUE® feature protects the generator and improves its performance by diverting unwanted stresses from the wind safely to the turbine's tower through the main frame. This design, which is already available in Alstom's onshore

turbines, separates the turbine rotor and generator. Two solid bearings transmit the main bending loads to the tower, while a flexible coupling ensures that the generator rotor receives only the turning force, the torque. This allows the minimum sufficient air gap to be maintained between the generator rotor and stator at all times, producing maximum electrical efficiency.

Innovation and performance

Partial discharges in GIS can impact reliability, so they have to be constantly measured. Alstom Grid has developed its PDwatch solutions to do just that. The city of Nice is installing a demonstration microgrid system. It will use Alstom Grid's DERMS system to interconnect smart homes, industrial buildings, solar panels and energy storage while connecting the microgrid to the main distribution network. Grid codes define the requirements for parties connecting to the electricity network. They vary from country to country and even within a country. Harmonisation is under way, driven in part by the advent of wind energy. ■

Measuring partial discharge in GIS

As customers increasingly push to adopt condition-based maintenance for Gas-Insulated Substations (GIS), new opportunities are arising for periodic or permanent measurement of partial discharge.

Traditionally, high voltage substations are air insulated. But the clearances required between phases and between phases and earth are huge. This results in rather large installations, making them difficult to house in urban environments where space is at a premium. To overcome this constraint, a parallel technology was developed, the Gas-Insulated Substation (GIS), using a gas, for example sulphur hexafluoride (SF₆), at high pressure. SF₆ has excellent dielectric properties and is used as the insulating medium between the phases and between the phases and earth. As a consequence, a GIS is much more compact. In fact, gas-insulated substations can be down to one-tenth the size of their air-insulated cousins, depending on the voltage level. The use of gas insulation in the power

system network has developed rapidly thanks to its compact nature, low maintenance requirement and reliable operation. But the reliability of the GIS equipment can be undermined by the presence of free particles that originate mainly from the mechanical vibrations, from moving parts in the system such as breakers or disconnectors, or even from the manufacturing process.

According to David Gautschi, Alstom Grid electrical engineer, "they are rare, but can locally generate high electric fields exceeding the structure's design limits and initiate partial discharges (PD) forming free electrons and ions in the insulation. Repeated partial discharges are capable of triggering a progressive carbonisation of spacers that can slowly build up over years until they produce a flashover, or failure of the switchgear insulation struc-

ture resulting in the entire installation, or parts of it, being shut down." Repairs – often involving the manufacture of specific parts – can take several weeks to complete.

Measuring partial discharges

When partial discharges occur (resulting in voltage drops of less than a nanosecond), they generate electromagnetic waves that propagate through the switchgear. These waves can be measured by means of dif-





ferent technologies operating in a variety of frequency ranges. Detecting partial discharges in lower frequency ranges can be carried out by taking measurements with acoustic sensors. Says Gautschi, "In the medium frequency range, between a few kHz and a few MHz, measurements

are usually made by means of a coupling capacitor. The disadvantage of using this device is that it is large and not suitable for online monitoring. However, partial discharges in pressurised gas can be measured in the Ultra High Frequency (UHF) range between 100 MHz and 2 GHz. The added advantage here is that this allows the whole substation to be permanently monitored and the location of PD activity can also be pinpointed." Demand

for this level of monitoring is particularly high in the Middle East, though less pronounced in Europe, where utilities are more hesitant to make the additional outlay required.

UHF range measurements

Different types of equipment are available to carry out measurements in the UHF range. Alstom Grid has developed its own solution, called PDwatch. →→

→→ The centre of competence for the PDwatch product is located in the BHT unit in Aix-les-Bains, France. The PDwatch system can be used either for periodic measurement (PDwatch portable) or for permanent (online) condition monitoring. The second method has the obvious advantage of tracking all partial discharge activity over time and therefore offering a better basis on which to decide when maintenance is required rather than relying only on spot checks using a portable system. “The benefit of measurements in the UHF range is the effective avoidance of external noise,” explains Jean-François Penning, PDwatch project manager. The frequency range can be chosen to measure

🏠🏠 The PDwatch Portable offers frequency spectrum and time analysis. 🏠🏠

in a band with low external noise. The suppression of external noises, for example in the GSM mobile phone range, can be achieved in the following way: the measurements made by the sensors fitted in the GIS are compared with the results of those installed in other compartments or those of an additional external antenna. This method avoids using additional band stop filters on the input ports, as generally required by standard wide band monitoring systems. It also maintains a good signal level. Once the partial discharge activity has been measured, the next task – and the more complicated one – is to interpret the partial discharge patterns and classify them into degrees of severity. “Part of the complexity is that partial discharge patterns will vary according to the switchgear design,” notes Gautschi. “So it is essential to have access to the manufacturer’s database to make sure that partial discharge information will be accurately interpreted. Alstom Grid is going to make its databases available to customers.”

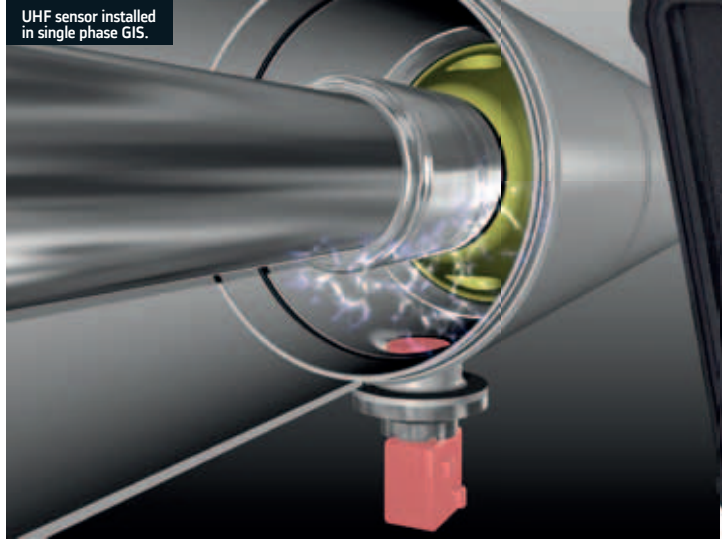

UHF sensor installed in single phase GIS.



Outdoor application of the above sensor.

PDwatch Online partial discharge monitoring

The PDwatch Online UHF monitoring system records and displays the UHF signals generated by partial discharges in a gas-insulated substation. It is permanently fitted into the substation and can be interrogated remotely at any time. This makes it possible to detect and eliminate emerging dielectric faults before a flashover can occur. Used with suitable sensors, this system can detect critical defects such as particles, coronas,

free potentials and insulator voids. It can also be programmed to generate alarms at specified absolute value and time thresholds. “The latest system is very advanced,” points out Gautschi, “and uses fast algorithms to provide very high accuracy.”

PDwatch Portable UHF detector

PDwatch Portable is designed to measure campaigns in substations at the commissioning stage or periodically in the course of the substation’s life. It is a two-in-one



The PDwatch Portable UHF detector records and displays the UHF signals generated by partial discharges in a GIS.

device, offering frequency spectrum analysis and time analysis. By using this equipment at regular intervals, developing dielectric faults can also be detected and eliminated before complete breakdown occurs. The portable UHF detector and its laptop PC are fitted into a travelling case and supplied with all necessary cables and accessories.

PDwatch Manager

This software tool enables event records to be managed while at the same time facilitating defect recognition. It can be used locally on the central unit's human-machine interface (HMI) PC or run from a remote PC via the Internet. It includes a constantly updated library of partial discharges that helps to identify PD patterns. It has the added advantage of saving users a considerable amount of time by generating test reports automatically. ■

MORE



David Gautschi

SENSORS FOR MEASURING PARTIAL DISCHARGE ACTIVITY

Different types of sensor can be used to measure partial discharges in a gas-insulated substation. Alstom Grid's latest design uses a conical antenna with a small footprint. Its sensitivity has been tested under laboratory conditions in different calibration cells as well as after having been installed in the switchgear. It offers an extremely high degree of accuracy and high linearity. Furthermore, the cost of the device has been dramatically reduced and its small footprint now allows it to be retrofitted to older substations. Its output has an integrated low frequency cut-off so that no power frequency voltage is visible on the sensor connector. The output can also be adapted to meet customer needs, and it can, for example, be used as a conventional voltage detector to detect whether a particular phase is energised or not.

The new sensor has been fitted in all types of Alstom Grid gas-insulated substation and tested for use in retrofit projects. These latest developments have resulted in an adapted version of the sensor being used in large power transformers to monitor partial discharges in oil. This version has been installed in 800 MVA transformer poles of the Swiss utility Alpiq. The transformers have been in service since 2011.

During the development of the sensor, the existing calibration methods for GIS sensors were tested, and a new high performance calibration cell has been developed to carry out tests when no bays are available to carry out this procedure in situ.

MICROGRID ENERGY MANAGEMENT

PRODUCTION, STORAGE AND CONSUMPTION

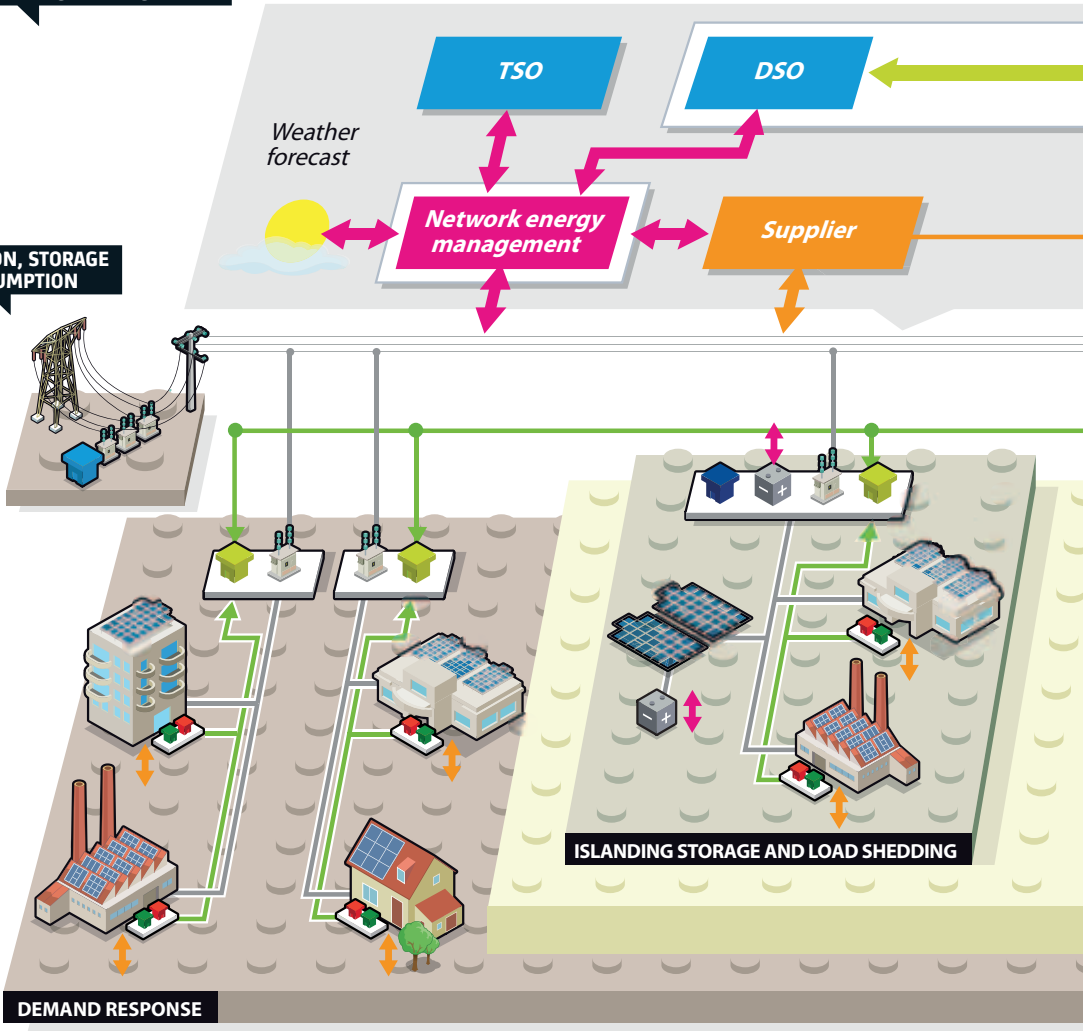

Nice Grid – testing the future

Fast Company has called Microgrids “the impatient upstarts of our energy future”. It describes them as independent, small-scale electricity systems for communities, towns, campuses and even individuals, delivering integrated distributed renewable energy, improved grid reliability, personal energy usage data and customised control.

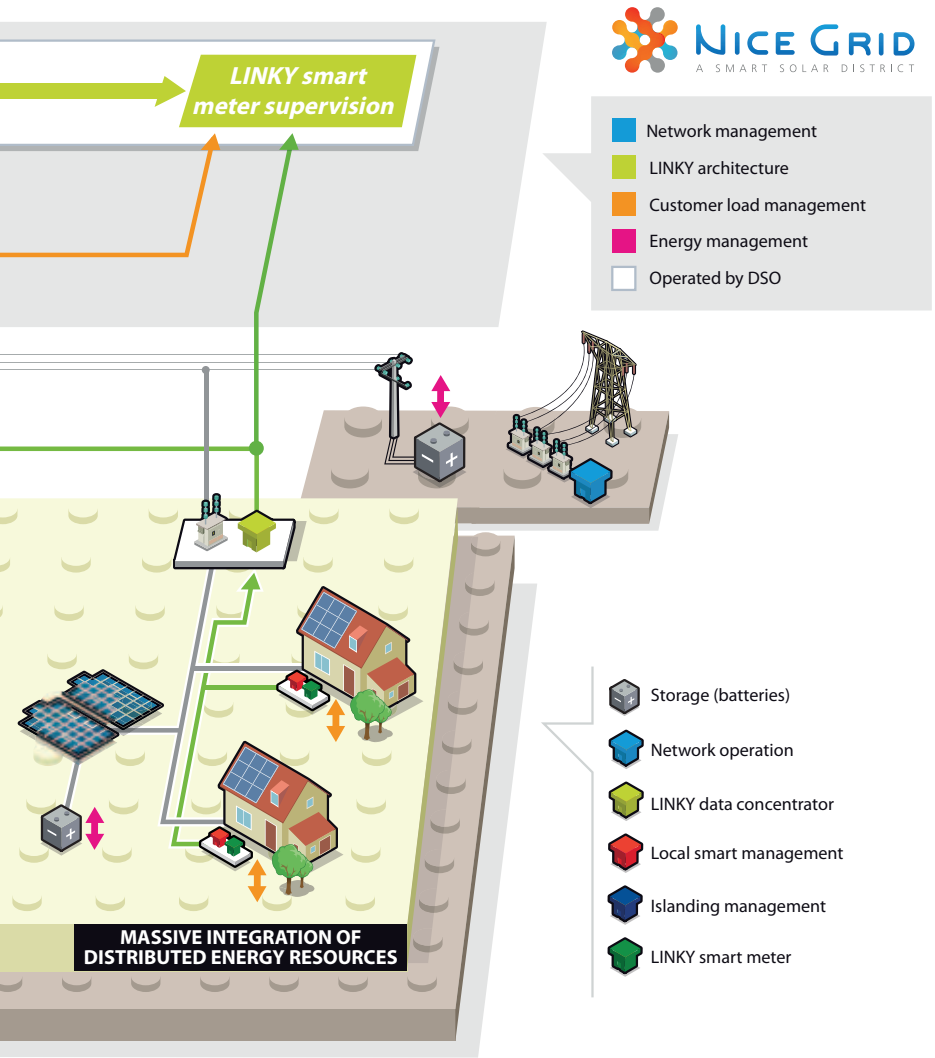

The objectives of Nice Grid are threefold: to test massive photovoltaic integration; enable islanding for secure supply; and provide demand response for flexible consumption.

Although they are a hot topic, few fully commercialised state-of-the-art microgrids with significant generation capacity are actually up and running. Nice Grid, a living laboratory located near Nice in the south of France, is one of the rare demonstrations of microgrids in the world. The project, which is expected to last four years, brings together ERDF (the French distribution

network operator), EDF (the electricity supplier), Alstom, battery maker Saft, and other industrial partners and innovative SMEs. The project has been selected as one of the six smart grid demonstrators of the European Union's Grid4EU programme. It will test an innovative architecture for medium and low voltage distribution networks with smart houses capable of man-

aging their electricity needs and new architectures called Virtual Power Plants to run them. A total of 1,500 residential, commercial and industrial end users are expected to participate in the experiment. The Nice Grid project is one of 15 smart grid demonstration projects in which Alstom is actively participating around the world. The project will study and →→

MORE



☞ Said Kayal

MICROGRIDS TODAY...

The balance of energy on the grid will rely on larger volumes of distributed energy resources (renewable energy, demand response and storage). Because today's distribution network does not accommodate these new types of energy flows, smart local optimisation is needed, while maintaining the quality and security of energy supply.

... AND TOMORROW

Microgrids are the building blocks of tomorrow's smart cities. They take full advantage of the flexibility of "prosumers" (consumers who also produce electricity) while integrating new distributed energy resources and storage solutions. Fragile areas susceptible to blackouts, as well as densely populated cities, will eventually be made up of autonomous grids within an overall smart grid able to survive major disturbances.

Tomorrow's energy management systems will be designed around a decentralised, multilayer architecture, where microgrids provide the local intelligence and optimisation. New sources of renewable energies such as biomass and microhydro solutions, as well as new storage solutions, will be integrated at the local level. Local microgrids and smart campuses will be part of smart districts, which in turn will be part of smart cities, with each layer optimising the layer below to build up the overall smart grid infrastructure.

→→ test the economic, technical and social issues related to microgrids of the future. These include the optimisation and use of medium and low voltage networks with a massive contribution from decentralised and variable renewable energy sources (principally photovoltaic) as well as the behaviour of customers, who will become agents for their own production, consumption and storage of electricity. Also to be studied is the operation of an independent consumption zone equipped with energy storage resources and isolated from the main network.

DERMS

"Nice Grid will use the Alstom Grid Distributed Energy Resource Management Solution (DERMS) to interconnect smart homes, smart industrial buildings, energy storage and a large number of solar panels, gathering them into a single integrated microgrid," explains Said Kayal, Smart Grid Innovation Manager at Alstom Grid. "DERMS will allow for more optimised energy consumption in the

☞☞ Nice Grid will interconnect smart homes, smart industrial buildings, energy storage and a large number of solar panels. ☞☞

microgrid and connect it to the main ERDF distribution network. The current distribution network is unable to accommodate this new type of energy flow, so local optimisation and balance between production, consumption and storage appears to be the right approach to avoid massive investments in the distribution network," he adds.



Connected to the microgrid?

ERDF and EDF have to integrate distributed energy resources (DER) into their daily grid and commercial operations. Nice Grid will attempt to answer their



A nice place to be when the sun shines.

→→ business needs in terms of DER enrolment, optimisation and dispatch around an MV/LV grid node.

Overcoming the challenges

The south-eastern region of France where Nice Grid is to be located is an “electric peninsula”. It produces only 40 percent of its energy needs for the moment, but it already has a high concentration of solar panels connected to the grid, making it an ideal location for experiment. The demonstration will capture around 2 MW of installed photovoltaic capacity in the region. In extreme situations, the microgrid can also be islanded. This principle works on the basis that if the distributed network experiences a blackout or other extreme conditions, the microgrid will continue to draw power from internal DER (solar panels, storage or demand response), as it is an independent autonomous network.

“One of the key challenges of the project includes the smooth injection of decentralised and intermittent renewable energy into the distribution grid, and its management. The project integrates storage systems

interactions between energy actors: consumer, commercial aggregator, and the distribution system operator (DSO) at the microgrid level.

The DSO (ERDF) will be able to route

🏠 Customers will become agents for their own electricity production, consumption and storage. 🏠

tems and centralised demand management centres in order to achieve this; however, energy optimisation via storage solutions will be pushed to the maximum,” Kayal specifies.

Another key challenge of the project is to enable consumers to become active participants in the local energy balance via demand response. Nice Grid will attempt to design and validate a new model of

energy to where it is needed, and end users will be able to monitor and control their energy consumption via smart meters. In this way, the Nice Grid project will demonstrate the impact of lowering energy demand and reducing CO₂ emissions, while maintaining the quality and security of the network, acting as a kind of laboratory for experiments that are not possible on a working national grid. ■

Wind power helps push grid code harmonisation

In a deregulated electricity market, grid code harmonisation is a necessary step towards maximising network efficiency and fair competition among suppliers. Wind farm integration into the system is likely to accelerate the trend.

Relationships between a power transmission system operator (TSO) and all the users of the transmission system are set out in a document called a “grid code”. This term is commonly used to refer to the suite of codes, rules and laws that define the technical requirements for parties connected to public electricity systems – suppliers, consumers, generators and operators. It specifies day-to-day procedures for both planning and operational purposes and covers both normal and exceptional circumstances.

Historically, each TSO has developed its own grid code. A country may have a single grid code (France, for example) or several (as in Germany). Generally, these codes are today harmonised in

☞ A powerful driver comes from the wind energy industry. ☞

each country leading to what can be called “national codes”. Some are very precise (over 600 pages for the UK grid code), others concise (30-40 pages for one of the German operators). Yet, they all have more or less the same framework, covering definition of technical, design and operational criteria for grid access and use, planning for grid development and reinforcement, system operation criteria and standards, scheduling and dispatch of

supply and demand resources, data exchange, and metering policies and systems for power and energy transactions in the grid.

Market deregulation changed the landscape

For decades, these national grid codes adapted easily to the growing international transfer of electricity. “Things became complicated with market deregulation, when more and more players entered electric systems, and different private

and public power producers or utilities connected to the grid,” explains Daudi Mushamalirwa, Alstom Grid Network Consulting Manager. As a result, to design,

build and operate its products on a large scale, a power industry company has to consider a range of grid code requirements from a variety of countries. Even though the same voltage levels and synchronous frequencies (50 Hz or 60 Hz) are used across the globe, their operating values generally differ. “This is the case even inside Europe,” adds Mushamalirwa. “For example, the allowable voltage variation





at 400 kV is between -10% and +5% in Austria, between -8% and +10% in Germany and between -13% and +5% in Ireland.” Developers that operate in more than one country have to decipher and understand a number of grid codes with clauses that are formulated differently yet perform essentially the same function. Moreover, code requirements can often be insufficiently clear or not always technically justified or economically sound. Manufacturers frequently have to develop tailor-made software and hardware to achieve compliance in a particular region, whereas a common approach could deliver a technically equivalent solution. This results in unnecessary extra costs and efforts from the power industry.

Wind energy: a powerful driver for harmonisation

Deregulation and internationalisation of electricity networks have led to an increasing need to develop a harmonised set of grid code requirements. This is under way at the international and European levels through standardisation efforts by associations such as the European Network of Transmission System Operators for Electricity (ENTSO-E), which groups 41 TSOs from 34 countries. Harmonisation is progressing slowly. “However, a powerful

driver comes from the wind energy industry, which urgently needs code clarification and unification,” says Mushamaliwa. The operation of nuclear, fossil-fired or hydroelectric power plants can be planned and controlled in order to meet the daily load curve of the electricity demand on the grid, but the situation is not the same with power plants using renewable energies such as wind (or solar) energy, whose operation is dependent on weather conditions and can be controlled only in a limited way. There are also potential reliability concerns if a large amount of wind power trips off the grid because of grid faults. And as wind power is becoming a major generation source across the EU (a wind energy penetration level of 12 percent is expected in 2020), “there is also some desire that wind contribute some grid support services such as reactive power or frequency and voltage control.”

According to the European Wind Energy Association (EWEA), harmonised technical requirements will maximise efficiency for all parties, and should be employed wherever possible and appropriate. This harmonisation strategy will be of particular benefit for manufacturers, who will be required only to develop common hardware and software platforms; for developers, who will benefit from reduced equipment and connection costs; for consumers, who will benefit from lower costs; and for system operators, especially those who have yet to develop their own grid code requirements for wind power plants. ■

MORE



🔥 Daudi Mushamaliwa

ALSTOM GRID, PART OF THE FRENCH TASK FORCE FOR WIND FARM GRID CONNECTION

Gimélec, the French association for electrical equipment, automation and related services that brings together 230 companies from the electrical industry, is launching a “task force” in order to support the grid connection for wind farms in France and its interest in fair competition. “As an influential member of Gimélec, Alstom Grid will be one of the leaders of this task force, whose objective is to make the French electrical industry into a forceful lobby and have a strong voice in setting up regulatory requirements and incentives for wind power and other renewable energy plants,” says Daudi Mushamaliwa. Promoting the electrical industry’s point of view is essential to ensure that grid code requirements are comprehensive and transparent so as to avoid misinterpretation and make sure they are as explicit as possible and include clear, commonly shared definitions of the terms used for wind turbines, wind farms and other equipment. Requirements should also focus on the essential aspects of technical performance, leaving an opening for ancillary services; they should balance cost and benefits of technical performance, and generally be specified so that these can be met at minimum overall system cost. Ultimately, requirements for wind power plants should not be excessive or discriminatory.



Smart products and services

Transmission systems have changed rapidly due to technology advances, regulatory pressures, the surge in renewable energy and the arrival of microgrids. These advances are now being transferred to distribution networks. A new technology centre in Shanghai is capable of testing thyristor valve modules that are based on six-inch thyristors and weigh over 20 tonnes. The New Zealand utility, Transpower, commissioned Alstom Grid to design and develop a special reactive power compensator to be installed across its national network. ■



Transmitting the benefits of automation and protection technologies

The emergence of smart grids initially concerned transmission networks, but many of the issues identified in this sector are likely to be important in distribution systems too. For this reason Alstom Grid is looking at experience and techniques from transmission automation and protection that can be applied to the design and operation of distribution networks.

Automatic devices for protecting electrical systems date from the 1830s, long before commercial power systems were developed, and even some modern devices for system protection still apply concepts that were developed almost a century ago. The high reliability demanded of protection technologies means that well-established approaches still have their place, and the

introduction of any new concept is a milestone. That said, change is rapid and accelerating in the transmission and distribution sector due to a combination of technological progress (especially in computer hardware and software), regulatory pressures, client demands and the growing importance of DC grids, as well as distributed inputs from

renewables and microgrids operating in parallel with the main network. Transmission has taken the lead in this, and many of its innovations in protection have been adopted or are being explored for distribution, too. According to Ponniah Sankarakumar, Regional Marketing & Business Development Director for Alstom's Substation Automation →→

→→ Solutions, “imagination is the only limit to the extent transmission protection technology can be transferred to distribution, although it is always reasonable to start with what’s obvious.”

Transferable technologies

First on his list is flexible/Programmable Scheme Logic (PSL) to optimise facility utilisation by allowing relay users to configure an individual protection scheme to suit their particular application. The execution of the PSL is event-driven, meaning the logic is processed only when any one of its inputs changes, and only that part of the PSL that is affected by the change is processed.

Another promising avenue according to Sankarakumar is to use functions already found in transmission systems to build more supervision into distribution level devices. “This would mean earlier triggers for predictive maintenance, which in turn would improve the three Rs: reliability, resilience and responsiveness of the system as a whole.”

Load management can also benefit from increased automation. In order to minimise the effects of under-frequency on the system, a multi-stage load shedding scheme may be used, with the plant loads prioritised and grouped. During an under-frequency condition, the load groups are disconnected sequentially, with the highest priority group being the last one to be disconnected. Automation can help to define the optimal length of time that loads are disconnected while making sure not to reconnect loads that will cause the problem to occur again immediately.

Communication is key

Information exchange is fundamental to all the new techniques, and protection relays need to offer modern communication protocols such as IEC 61850. In this protocol, substation physical devices are accessed via Ethernet, and the actual devices are a collection of logical devices made up of logical nodes. These logical devices can be mapped to specific com-

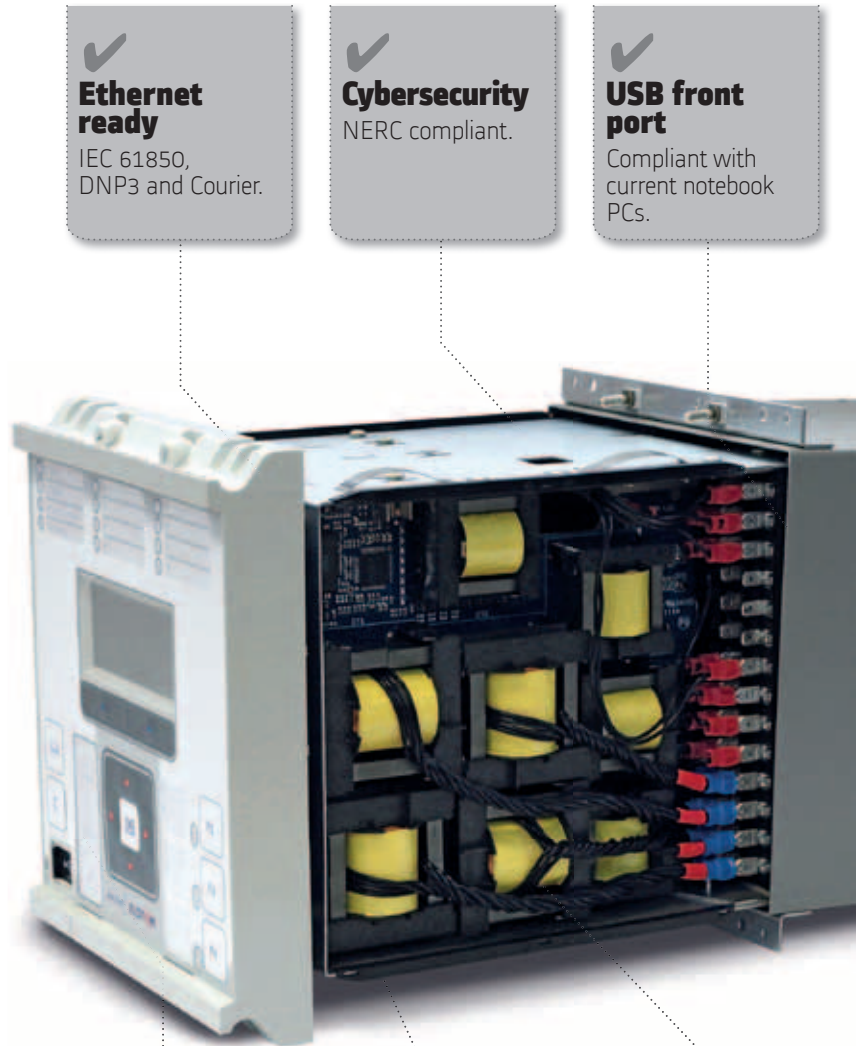

✓
Ethernet ready
IEC 61850, DNP3 and Courier.

✓
Cybersecurity
NERC compliant.

✓
USB front port
Compliant with current notebook PCs.

✓
Unloaded
Lead-free components, lead-free process.

✓
No battery
No heavy metal.

✓
High level of recyclability
Target more than 60%.

✓
**Shipping
carbon
footprint**

Minimised transit weight and volume.

✓
**In-service
carbon
footprint**

Reduced power consumption.

Many innovations in protection are being explored for distribution.

and protocols, for both critical and non-critical communications, among each other and to other networks, too. However, although shared protocols and standardised hardware present numerous advantages for network design, control and reliability they also have some drawbacks, and present a whole set of new issues. Because the various hardware and software components are well known, cyber attacks are made easier, and they can simultaneously target a number of installations all using similar equipment. As Sankarakumar points out: "Protection relays are now IEDs, intelligent electronic devices, and we have to have secure communications within substation environments to balance the needs of interoperability and cyber-security. One way we're doing this is to incorporate cyber-security measures into IEDs, in line with emerging standards, to increase the reliability of the system."

Major benefits can be reaped when transmission protection technology is built in to distribution relays. But an experienced partner (such as Alstom Grid) is needed because, as Sankarakumar emphasises, "we must take care of constraints such as size, withdrawability, cost and the suitability for refurbishing previous generation relays, so that the benefits can be realised." ■

The MiCOM Agile bridges the gap between transmission technologies and distribution systems.

munication services such as GOOSE (Generic Object-Oriented Substation Events) that can bypass the TCP/IP protocol to present substation events in real time and support the exchange of a wide range of common data organised by a dataset. With the universal availability of modern interfaces in laptops for parameterisation and troubleshooting, the need for extra hardware is reduced.

Electricity networks would have remained expensive, specialised and limited if they had had to rely on proprietary technologies and software as in the old days. The control systems of electrical grids used to be isolated, using systems that were incomprehensible to the outsider, but now they can be linked using standard IT infrastructures

MORE



■ Ponniah Sankarakumar

MiCOM P40 Agile: RELIABLE, RESPONSIVE AND RESPONSIBLE

The energy sector is facing pressure from regulators and citizens alike to reduce its environmental impact and act more in accordance with the principles of social responsibility. Efforts to combat greenhouse gases and other forms of air pollution receive the most attention, but Alstom Grid is helping to improve performance at each link in the production, transmission and distribution chain.

The MiCOM P40 Agile protection relays provide a practical example of what can be done. The P40 is redefining protection relays for a smarter, more efficient energy future not just by operating more efficiently, but also in its design and manufacturing.

The MiCOM P40 Agile is 85 percent recyclable and is manufactured in a lead-free process. Power dissipation is the lowest among comparable products, and the device does not need any resident battery, thereby eliminating a source of heavy metals and a potential source of non-reliability. Even the product weight, including packaging, has been optimised to reduce the carbon footprint during transit. It detects and shuts off downed overhead lines, avoiding potentially fatal accidents. The P40 Agile protects networks, but it also protects people, animals and the environment.



The test hall at Alstom Grid's China Technology Centre.

Brazil's Rio Madeira hydro project will be using new thyristor valves designed by Alstom Grid and tested in a gigantic new test facility in China that is one of the few places in the world capable of carrying out such complicated work.

Big new thyristor valves meet big new test centre

China and Brazil have a lot in common. Both economies are growing fast, both countries cover huge areas, and both have considerable hydroelectric potential. Unfortunately, in both cases the hydro dams are thousands of kilometres away from the economic powerhouses. That is why the world's longest HVDC transmission line is in China, bringing power from the Xiangjiaba dam to Shanghai, 2,071 km away. But China won't hold the record for much longer, since next year the 2,375 km Rio Madeira line will carry electricity from the Amazon

region to São Paulo, the world's tenth largest city in GDP terms.

As a world leader in hydro equipment and services, Alstom is a key player in both the above projects, designing and implementing solutions for the challenges such vast networks pose. And as Russell Preedy, leader of Alstom Grid's Valve Design group in Stafford, UK, points out, it is not just the distances that are growing: the transmitted power of HVDC schemes is increasing rapidly too, with both current and voltage now at levels never seen before in the market.

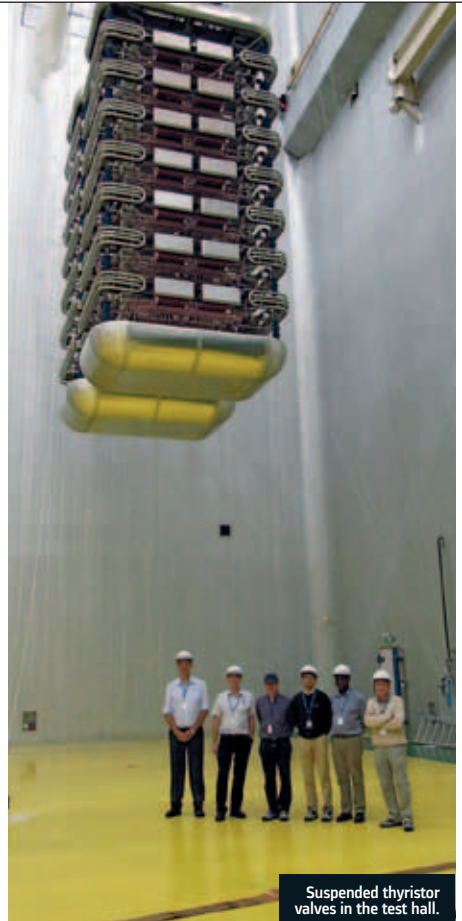
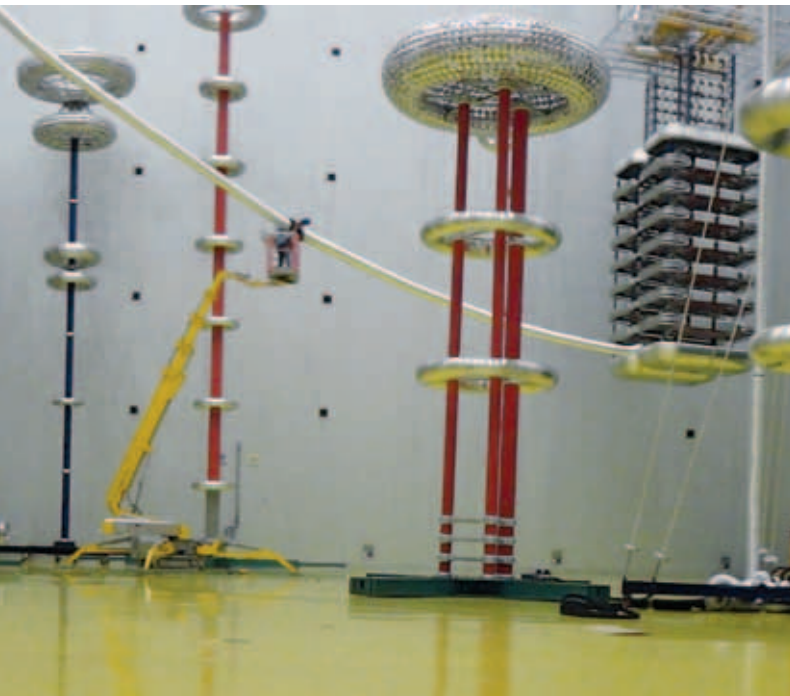

Suspended thyristor valves in the test hall.

“This has a considerable effect on the design of the main items of high voltage equipment in the HVDC station,” he says, “not least the high voltage thyristor valves that form the heart of the converter. Until recently few HVDC converters had operated at current ratings above 3,500 Adc because the largest-diameter silicon on which thyristors could be based was 125 mm (5 inches). However, 150 mm (6 inch) thyristors have recently become commercially available and are changing the rules with respect to current ratings.”

New thyristors, new challenges

As thyristor sizes increase, the HVDC valves need to be modified to accommodate larger devices to utilise the new technology. Alstom’s H400 series of thyristor valves has been designed to take advantage of both 125 and

150 mm thyristors. The H400 consists of a number of liquid-cooled valve modules, each comprising two “valve sections” of up to six thyristors, together with assemblies of damping capacitors and damping resistors to provide voltage grading, plus limiting reactors for rate of current change (di/dt) and gating electronics.

The five or six thyristors within a valve section are held together between high-efficiency liquid-cooled heatsinks as one clamped assembly. Glass-Reinforced Plastic (GRP) tension bands are used to tightly secure the assembly and to provide the high clamping load necessary for good electrical and thermal contacts between thyristors and heatsinks. The clamping system facilitates replacement of a thyristor without opening any power or coolant connections.

🔗 Six-inch thyristors have recently become commercially available. 🔗

A number of such modules are connected in series to make up a complete valve. For a typical large back-to-back installation, three modules are required per valve and the Multiple Valve Unit (MVU) consists of four valves associated with one phase of the AC system (a “quadrivalve”). To accommodate larger thyristors in the H400 valve, the thyristor heatsinks, clamping mechanism and →→

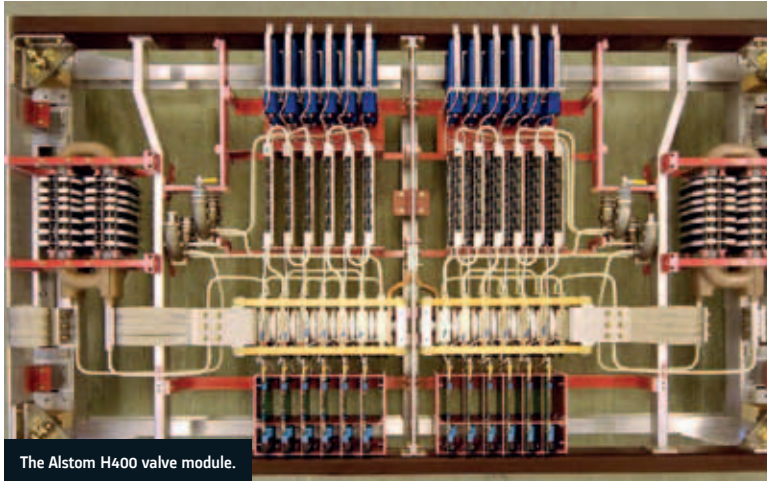

The Alstom H400 valve module.

→→ damping components all had to be up-rated. The higher clamping load requirement (up from 135 kN to 200 kN) meant that the clamping system needed to be re-designed, notably the GRP tension bands, the disc springs and the end spreader-plates (end-cheeks).

Designing systems to transmit DC over long distances poses numerous technical problems, for instance how to deal with ohmic losses. However, as Preedy points out, “the sheer size of the equipment involved also creates its own problems, not least how to test components weighing several tonnes.”

🏠 The equipment to be tested is extremely bulky. 🏠

Testing, testing

Alstom Grid’s Valve Test Facility (VTF) in Stafford can perform all periodic firing and extinction tests required by the standards, as well as limited dielectric tests up to 300 kV. The new €47 million China Technology Centre (CTC) in Shanghai focuses on UHV transmission, up to 1,200 kV AC and 1,100 kV DC, and smart grids. The facility has been designed to accommodate very large electrical equipment such as the new valves, with a UHV testing hall and R&D platforms that include scientific simulation tools, climate chamber, a temperature rise testing lab and material testing labs. One of the most striking things about the CTC test hall is that it covers 54,000 square

metres, but most of the space seems to be empty. Preedy explains why. “The equipment to be tested is extremely bulky to begin with, so you need a big building just to accommodate it. You’re testing valves weighing over 20 tonnes, suspended from the ceiling.

That’s why you see those large cranes. Then you have to add the cooling equipment, auxiliary test equipment and all the cables running back to the control cubicle. And there are very stringent requirements on clearance too, several metres in each direction, including above the test object in the case of the thyristor valves, and all that requires space.” The combination of architectural requirements, safety considerations, demanding specifications for HV power supply, and the vast amount of expensive supplies and auxiliary components means that very few test facilities in the world are actually capable of carrying out full dielectric valve type-tests on large valves. Preedy and his team are doubly satisfied, first because the tests prove that their design is capable of operating well beyond real operating conditions, and the new thyristor valves successfully underwent testing to criteria exceeding the requirements of IEC 60700. And second because the new test facility was being used for the first time, and it too passed with flying colours. ■



🌱 Russel Preedy

TAKING POWER FROM WHERE IT IS TO WHERE IT’S NEEDED

Alstom Grid has completed manufacture and testing of the first nine (of 28) HVDC converter transformers for Brazil’s \$15 billion project to harness the hydro power of the Rio Madeira, the Amazon’s biggest tributary.

The project is the cornerstone of the Brazil-Bolivia-Peru hub of the Initiative for the Integration of South American Infrastructure proposed by the governments of South America, and supported by Brazil’s National Development Bank.

The Rio Madeira project, started in 2008, is designed to help the country meet growing energy needs without boosting greenhouse gas emissions.

The converter stations will be integrated into the world’s longest DC transmission line, covering 2,375 kilometres, to connect the new hydro power plants of the Madeira River (Santo Antonio and Jirau) to Brazil’s south-eastern region, which has the highest energy consumption in the country.

The Alstom Grid bi-pole converter station will allow transmission of 3,150 MW over a 600 kV DC line, and will be integrated into a much larger power transmission system, connecting the Madeira Jirau and Santo Antonio hydro power plants to the Brazilian national grid.



The Christchurch/Islington 220/66 kV substation, one of the sites where the Alstom Grid RPC is installed.

Generic modularity for reactive power control implementation

Real-time power system simulation is vital for reactive power controller development and testing. Although commercial solutions exist, the uniqueness of their project prompted New Zealand's Transpower to commission a tailor-made solution from Alstom Grid.

The RPC simulator side by side with the Islington Local RPC.

On February 22, 2011, an earthquake of magnitude 6.3 struck Canterbury on New Zealand’s South Island, killing more than 100 people and causing extensive destruction. Underground power cables were badly damaged. Overhead lines and substations suffered too, but less.

Seismic activity is the aspect of New Zealand’s physical geography that has the most dramatic impact on the power sector. Major catastrophes are rare, but the country’s shape poses systemic problems for electricity transmission. As Alstom Grid Australia’s Project Engineering Manager Dr Ping Wang explains, “the network is long and skinny with major loads connected to generation centres by relatively long transmission lines. To maximise asset use, these lines are increasingly loaded to the point where they’re approaching their thermal capability.”

Voltage stability limits the maximum

🏠 The real-time simulator proved to be a key success factor. 🏠

utilisation of transmission line thermal capability. Planning studies by the national grid owner-operator, Transpower, show that the most cost-effective means of dealing with voltage stability and dynamic reactive power issues in New Zealand is to use dynamic shunt compensation, such as Static VAR Compensators (SVC), Static Synchronous Compensators (STATCOM) or synchronous condensers.

However, this means that the number of reactive power devices will increase in major load areas, and coordinating numerous dynamic and static devices is difficult. A Reactive Power Controller (RPC) can be employed to ensure optimal coordination, but no suitable equipment existed for the New Zealand configuration. So Transpower commissioned Alstom Grid to design and develop an RPC that would be installed first in Christchurch and subsequently throughout the whole national network. The final configuration will involve

multiple systems hierarchically grouped by region and area, communicating with the national SCADA system. For Dr Wang’s design team, the main challenge was to “devise a generic principle in both control concept and engineering implementation so that the design can be rolled out easily to other parts of Transpower’s network without major hardware and software re-engineering.”

The control algorithm has to be independent of a given substation’s physical topol-

🏠 Customer satisfaction is the best gauge of a project’s success. 🏠

ogy to be readily applicable to a wide range of installations. At the same time, control priorities have to be configurable to easily address the particular requirements of a

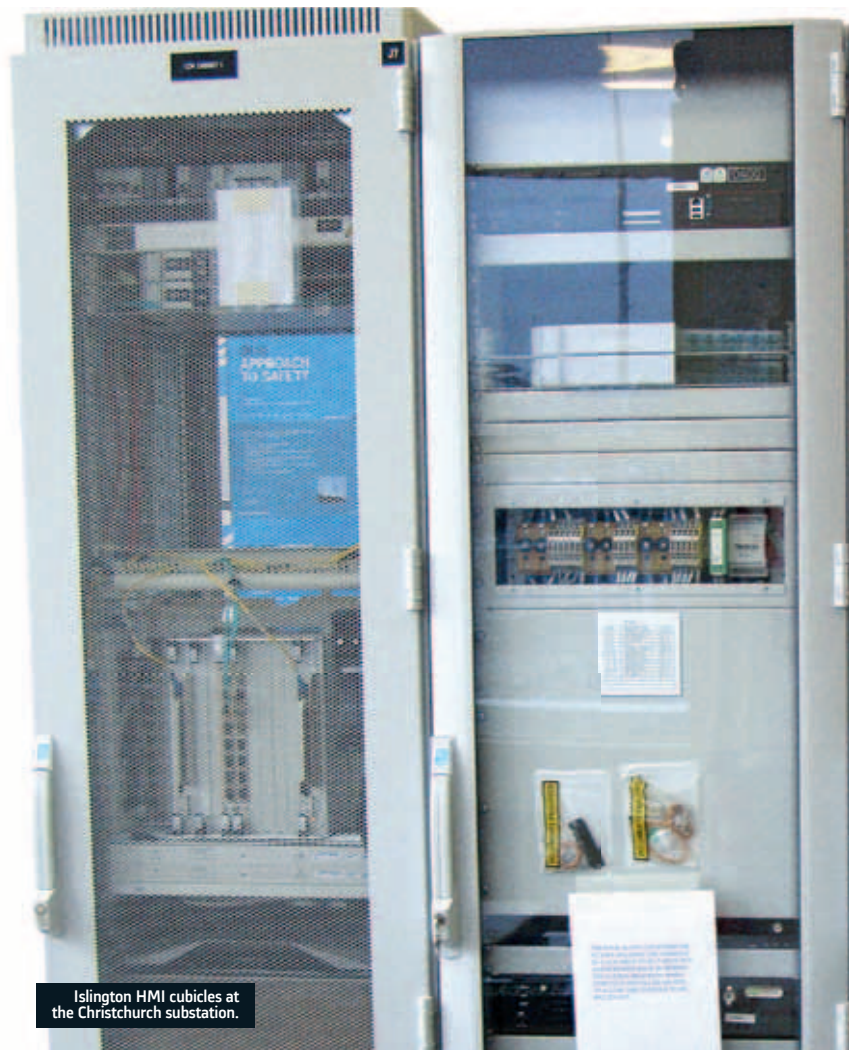

Islington HMI cubicles at the Christchurch substation.

given substation or area, or changed control strategies. In other words, what's needed is what Dr Wang describes as "generic modularity".

Real-time simulator

The stringent performance requirements and the critical role the RPC is required to play meant that the design and the control system had to be tested extensively with a power system interface that simulates the South Island system in real time. Buying or

renting a commercial simulator would have been expensive; and it would have required considerable effort to tailor an off-the-shelf product to the needs of the project. So Dr Wang and his team decided to develop their own simulator.

Their simulator contains detailed models of the substations, including all static and dynamic plant, transformers with on-load tap changers, switchgear and loads. It also includes a model of the South Island network reduced to a level where the simulator can run in real time but retains all crucial system characteristics. The final model closely matches the complete South Island system with regard to fault levels at the substations, reactive power and behaviour of dynamic plant, which was verified by detailed PSCAD/EMTDC® modelling.

The real-time simulator proved to be a key success factor for the RPC project. Due to the requirement for generic design and implementation, the RPC was type tested to prove its generality, expandability, changeability, and capacity to handle all types of plant, station topologies, system configurations and control strategies. After the successful completion of type tests, the simulator was then used to factory test the specific functionalities of the RPC for Christchurch production, and to fine-tune the control strategy and parameters. The tests lasted about six months.

The simulator was particularly useful for testing the RPC under abnormal system conditions because, as Dr Wang says, "many tests cannot be repeated during RPC commissioning due to power system security concerns and potential conflicts with Transpower's principal performance obligations."

Customer satisfaction is the best gauge of a project's success. Dr Ping Wang and his team are justifiably proud that Transpower is keeping the simulator – even after RPC commissioning is completed – as part of an RPC testing and development platform that can also be used to provide operator training, evaluate new control strategies before deployment, and support the addition of new substation equipment into the RPC scheme. ■

MORE



Dr Ping Wang

IMPROVING THE RPC SIMULATOR THROUGH FACTORY TESTING

Apart from verifying that the RPC met contract specifications and was fit for site installation, factory acceptance tests revealed unforeseen issues such as little-known characteristics of the firmware, and also allowed changes to be made that will improve RPC performance.

For example, because of unnecessary capacitor switching during voltage excursions, it would have taken four seconds for the RPC to return substation 220 kV voltage to within the deadband. The solution was to reduce the slope of the Static VAR Compensator local controller (not part of the RPC system) so that its deadband was lower than the RPC's. This ensures that the SVC will always use its full range in output to control the 220 kV voltage following voltage excursions, without having to first wait for the RPC to issue raise or lower commands. For minor voltage excursions, the voltage will still return to within the normal RPC deadband after a few hundred milliseconds. For major voltage excursions the capacitor would be switched to assist voltage control after four seconds via the RPC voltage control loop.



Consumption management as part of grid management

Three specialists give their views on consumption management



“Consumption is fragmented, distributed and inhomogeneous.”

Prof. Wil Kling

What are the drivers for managing consumption?

The main drivers are the economy and the environment. The success of environmental policies and carbon reduction targets depends on effectively managing consumption, while electricity producers need to shave peak demand for cost reasons. In addition, distribution system operators (DSOs) can leverage consumption management to increase asset utilisation. Smart grids create opportunities for close to real-time adaptation of demand to the actual system status.

What are the challenges with managing consumption?

Consumption is fragmented, distributed and inhomogeneous, especially with residential users, who account for one-third of total demand. The challenge is to zoom in on the flexible (non-critical) portion of consumption and influence the behaviour of consumers through price incentives or automated actions.

What is your experience of consumption management?

My 30 years in the industry made me aware of the importance of consumption management and demand response. And as a professor now, I lead research programmes that include demand-side management and demand response. Simulations and pilot projects show that demand-response mechanisms can provide considerable support for the integration of renewable energy sources and help establish efficient electricity delivery systems.

What is the likely future for electricity consumption management?

Probably, aggregators will take over the role of consumption management by contracting services of large numbers of residential customers and coordinating them. Also, developments in process automation and two-way communication will stimulate an active participation in the demand side and local balancing of consumption and production.

What technologies and non-technical factors will contribute to effective

consumption management in the future?

Critical technologies are continuous two-way communications, optimisation algorithms and predictive control techniques. Other factors include user behaviour and effective environmental policies.



“Demand management is likely to expand as utilities increase their focus on customer service.”

David Sun

What are the drivers of consumption management?

The focus of consumption management is on demand response (DR), with natural extensions to distributed energy resources (DER). Long-term DR drivers are customer expectations for choices on how their energy usage is managed, as well as technology/business advances enabling those choices. With continued regulatory reform and smart grid projects, we can expect renewable integration and smart meter deployment to drive near-term DR/DER increases.

And what are the challenges?

While significant progress has been made in areas such as smart meters, communications, etc., there are still many technical and non-technical challenges. They include modelling

Technical University Eindhoven, the Netherlands
Professor Wil Kling, professor of Electrical Energy Systems



Alstom Grid
David Sun, Chief Scientist



Iberdrola SA
Miguel Angel Sanchez-Fornie, Director of Control Systems & Telecommunications



large numbers of distributed DR components, forecasting and scheduling of intrinsically stochastic DR, and monitoring and control of these devices in a multi-tier environment where dynamic aggregation and disaggregation are an operational necessity. These challenges reflect fundamental business transformation for grid operators, energy suppliers/aggregators, and classical utility customers.

What is your experience of consumption management?

We are seeing a trend among customers interested in DR and distributed energy resources. There are growing interests in renewable integration, improved asset utilisation including peak shaving, demand shifting, deferred capital investment and customer service. Even though DR is still relatively small, utilities want to be prepared.

What is the likely future for electricity consumption management?

Demand management is likely to expand as utilities increase their focus on customer service. Through a combination of technical and business innovations, consumers can become “prosumers” (producer-consumers) in the energy eco-system. Energy storage devices, distributed renewable generation, and DR will become an increasingly important type of energy resource.

What technologies and non-technical factors will contribute to effective consumption management in the future?

The integration of energy, information, and

communication technologies will provide the necessary technical foundation for DR/DER expansion. This will lead to expansion of control room IT needed to serve operators in the multi-tier operations environment. Other key contributors are regulatory reform and consumer awareness.



“Interoperability and telecommunications are critical for consumption management.”

— Miguel Angel Sanchez-Fornie

What are the consumption management drivers?

The strongest driver is the need to improve efficiency in energy consumption. But consumption will ultimately depend on the end users – who have to be given the capability to decide when and how to consume. Smart grids offer the opportunity to facilitate consumption management. They enable consumers to become active rather than passive and react to supply based on needs.

And what are its challenges?

Some technical challenges still persist. For example, we still need more R&D in energy storage. But much of what is needed to manage consumption is available. We have smart metering, which shows each customer’s consumption in almost real time, and also the capability to control consump-

tion of individual appliances. And we have the telecoms technology to transmit all this data. The real challenge in managing consumption is the regulatory environment, which is not keeping pace.

What is your experience of consumption management?

Iberdrola has focused on active demand response for some time. In Spain, we have been involved in important R&D projects to demonstrate technical feasibility. Iberdrola USA is also starting trials with demand response, including deployment of smart meters, and Scottish Power has carried out limited demand response trials.

What future do you see for electricity consumption management?

It will happen. Perhaps in different ways and at different times, but it will happen. It’s already under way in the United States. In Europe, it will depend on regulation and the advances of aggregation. However, industrial consumers are already implementing measures to manage consumption.

What technologies and non-technical factors will contribute to effective consumption management?

Interoperability and telecommunications are critical for consumption management and smart grids in general. But with more information exchange among devices, different telecoms technologies and interoperability standards, we must also take data privacy and cyber-security very seriously in systems design.

The 245 kV Fluobloc installed at Lyon, France, 1969.

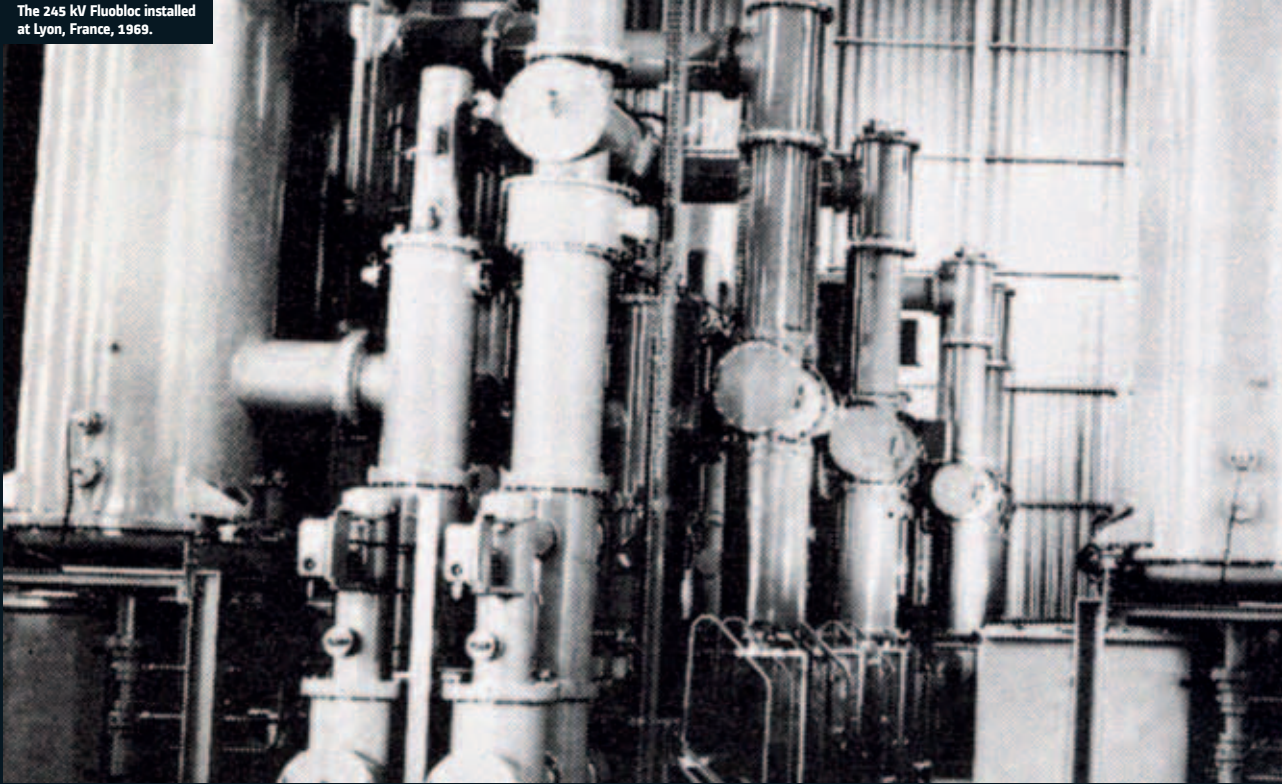

The history of gas-insulated substations

The gas-insulated substation (GIS) represents a key element of high voltage electrical transmission networks thanks to its reliability, low maintenance requirements and compact dimensions. Here is a brief history of its development and pioneers.



The world's first metal-clad 800 kV GIS, installed at Joshua Falls, USA, 1980.



The T155 GIS for 420 kV and 550 kV networks.

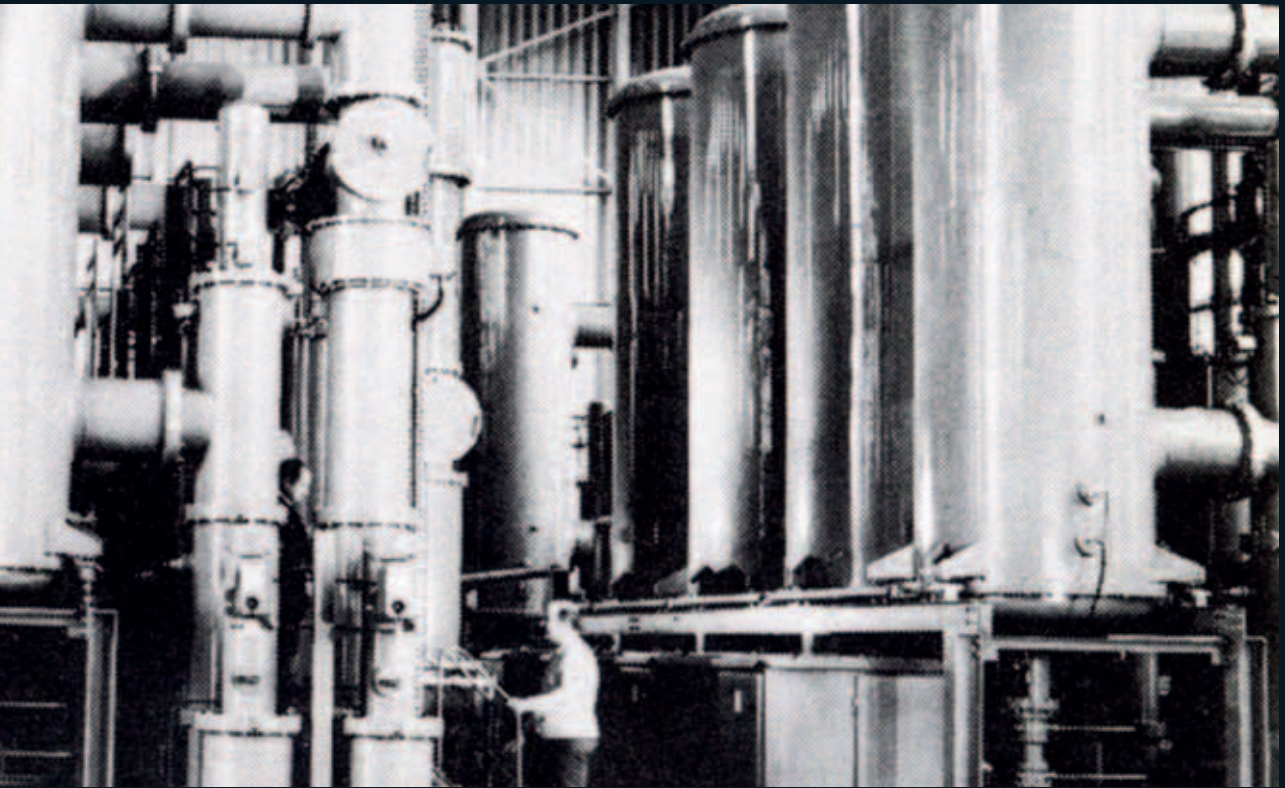

The roots of HV encapsulated substations go back to the metal enclosed concept of the 1920s when oil was used as the insulating medium. Compressed air and different gases were the focus of much research work, and the first Freon-based solution at 33 kV appeared in 1936. The following decades brought new versions until developments in industrial processes, chemistry and physics led the switchgear industry towards the end of the 20th century to the use of SF₆ for arc extinguishing and insulation as the main GIS technology.

SF₆ gas was already known during the 1940s. Westinghouse holds the original patent for the use of SF₆ as interrupting medium, and their engineers developed the first applications for switches and circuit breakers in the early 1950s.

In the 1960s all major manufacturers such as BBC-Calor Emag, Siemens, Magrini, Merlin-Gerin, NEI-Reyrolle, the Japanese

and Delle-Alsthom had started intensive developments on the basis of SF₆.

The dual-pressure SF₆ circuit breakers of the early GIS systems were soon replaced by single pressure, while circuit breakers were adopting puffer and combined thermal-puffer arc extinguishing chambers. The GIS focus was on the benefits of a compact indoor solution, protected from the environment and closer to users, whereas some markets preferred outdoor rugged solutions using hybrid GIS solutions.

The Alstom contribution

Alstom Grid has a rich GIS development history through its ancestor companies, Delle-Alsthom, Sprecher & Schuh, GEC and AEG.

Delle-Alsthom France started GIS development in 1958 and in 1966-1967 delivered a world first with its "Fluobloc" at 245 kV in several Paris substations, demonstrating the benefits of underground

GIS to supply bulk power close to city users. Achievements in the higher voltage ranges were subsequently marked by the deliveries of the first substations for 420 kV in 1976 and for 550 kV in 1977. Another "world first" was the completion of AEP's 800 kV GIS in Joshua Falls in 1979.

Sprecher & Schuh studied compact metal-clad installations as early as 1954 with oil insulation systems, but soon came to the conclusion that SF₆ gas insulation offered greater advantages. Their first GIS for 220kV was delivered in 1970 and the 145 kV, 40 kA in 1971. The original circuit breakers with double-pressure SF₆ systems (220 kV, 50 kA), developed together with ITE USA, were operated by the well-known Sprecher motor-wound spring operating mechanisms, which contributed to the success of subsequent GIS families. The exclusive third-generation FK mechanism today serves all Alstom Grid GIS products on the world market. →→

The 72.5 kV F35 GIS installed in Switzerland.

→ → AEG in Germany has also long been involved in GIS and SF₆, with its first GIS substation delivered in 1971. Meanwhile, GEC in England was collaborating with Siemens, and their first GIS was a 145 kV substation in London in 1982.

As GIS systems developed and their extensive use in HV networks grew, Alstom Grid became the manufacturer of complete GIS ranges of 72.5-800 kV in which single-phase and three-phase encapsulation is used.

Looking ahead

Clearly, the most significant development factor was the adoption of SF₆ as an insulation medium. This boosted the development of smaller switchgear requiring less operating energy and reduced materials and resources, leading to higher performance. So far 420 kV, 63 kA with a single break is possible with the spring mechanism.

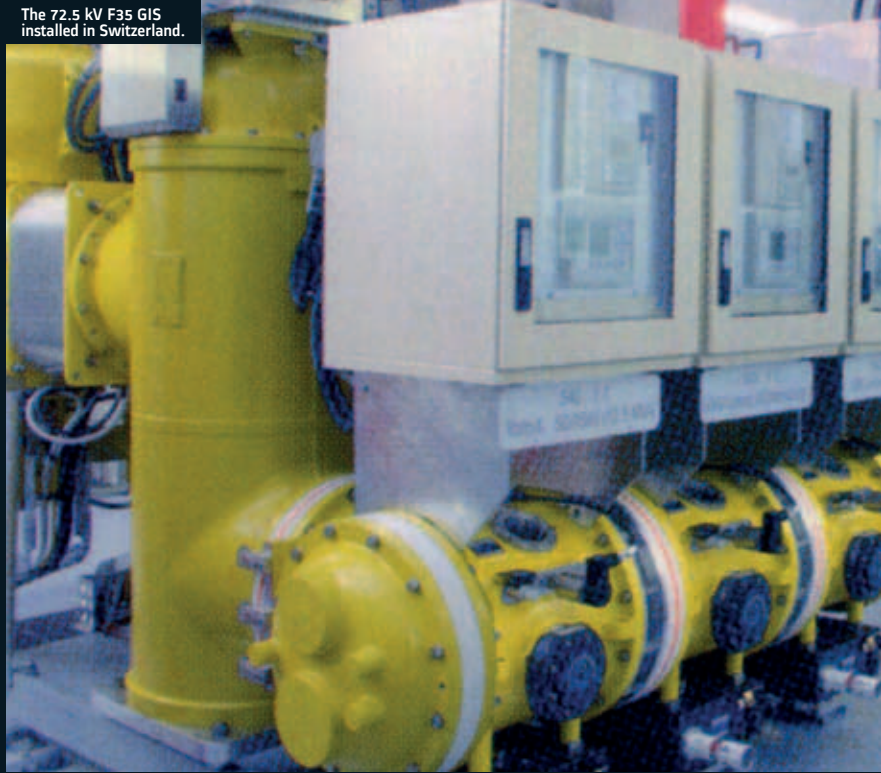

1920s

HV encapsulated substations (metal enclosed) using oil as insulating medium

1936

Freon gas used as insulating medium at 33 kV

1951

Westinghouse Electric applies for patent for the use of SF₆ gas as interrupting medium

Early 1950s

First SF₆ applications for switches and circuit breakers

1957-1961

GIS solutions with compressed air

1966-67

Delle-Alstom's "world first" 245 kV "Fluobloc" GIS

1967

GIS breakthrough – Siemens, BBC, Magrini, Mitsubishi

1970-1971

First spring mechanism-operated GIS by Sprecher & Schuh on the market

1971

First GIS produced by AEG for UW Neukölln Berlin

Late 1970s

First GIS type GMT I produced by GEC

1976

B 212 GIS systems circuit breaker. B 114 for use in the Swiss, German and Austrian railway networks at 110-132-170 kV and 16 2/3 Hz



After 50 years in the making, GIS development is accelerating thanks to the availability of simulation tools and the capability to integrate environmental needs into the design. Future trends could be influenced by the substitution of SF₆ technology, which, however, is likely to be a very complex task. Other steps have already been taken. Moving HV substations closer to consumers results in reduced transmission losses. Indoor GIS reduce the environmental influences on the switchgear, reducing maintenance needs and increasing lifetime. More and more “intelligence” is integrated into the GIS using electronic devices, forming part of digital substations. Ecological and economical considerations, together with ongoing technological developments have made even further optimisation of GIS conceivable. ■

MORE

👤 Endre Mikes

ROVING AMBASSADOR

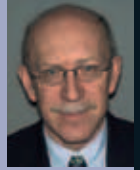

Endre Mikes was born and bred in Hungary. He studied in Budapest and Moscow, earning an M.Sc. in electrical engineering in 1968.

He came to Switzerland in 1970, where he was hired by Alstom Grid ancestor company Sprecher & Schuh in 1973.

“I worked in HV testing and CB development and then moved to GIS design and construction. Later, as consulting engineer, I contributed to industry bodies such as CIGRE, IEEE, etc.” It is thanks to his international contacts, technical know-how and linguistic versatility that he became globetrotting ambassador for the company. “In this capacity, I’ve witnessed the changing market focus over 40 years – first Western Europe, then the Far East, later the Gulf area, and since the fall of the Berlin Wall, Eastern Europe and Russia.

“In that time, I also observed major changes in the technology and design, in particular the reduction in size. Every 10 years or so, R&D came up with new designs, increased capabilities, better use of materials, advances in civil works that enable GIS to be installed underground, and now major improvements in the environmental footprint of our equipment. I foresee even greater changes in the not too distant future.”

1977

550 kV GIS in Ontario Hydro’s Clairville and Milton S/S by Alstom

1979

800 kV GIS by Alstom, another “world first” in AEP’s Joshua Falls S/S

1995-96

First single break 420 kV GIS CB B142 with hydraulic mechanism

2003

550 kV 63 kA T155 GIS Areva (Alstom Grid), the first and only spring-operated solution on the world market at this rating



T155 indoor.

2003-2004

Creation of the new F35 family, with the smallest footprint and building volume

2012

20,000 GIS bays by Alstom for reliable energy supply

FURTHER READING

If you would like more details on some of the topics in this issue of *Think Grid*, you might want to read the publications shown here.

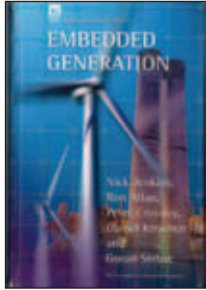

Embedded Generation

Authors: Nick Jenkins, Ron Allan, Peter Crossley, Daniel Kirschen and Goran Strbac
Publisher: The Institution of Electrical Engineers (2000)

Power System Stability and Control

Author: Prabha Kundur
Publisher: McGraw-Hill (1994)

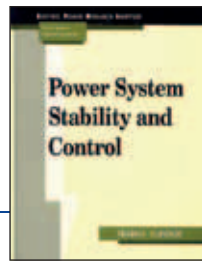

Generator Circuit Breakers Handbook

Publisher: Alstom Grid



2011 Electric Grid Full Report (MIT)

(from http://web.mit.edu/mitei/research/studies/documents/electric-grid-2011/Electric_Grid_Full_Report.pdf)

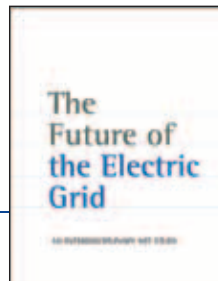

SEE ALSO...

[HTTP://WWW.EPE-ASSOCIATION.ORG](http://www.epe-association.org)



The European Power Electronics and Drives Association (EPE) is a non-profit organisation that runs academic conferences in Europe every two years.

It brings together some 1,000 delegates, making it the largest and most important conference on power electronics, electrical drives and industrial applications. It is a unique forum of international exchange on the state of the art and future developments in these fields and an excellent opportunity to stay up to date thanks to high-quality contributions from industry and academia worldwide.

The forthcoming EPE conference will take place in Lille, France, in September 2013 and will have as its main theme "clean transportation". The EPE also issues a journal and a newsletter.

27
“ AUGUST 27–31, 2012
PARIS, FRANCE
 Cigré Technical Exhibition

This biennial event, the leading exhibition for power system experts, is bigger this year to make room for some 200 exhibiting companies. The main themes for this year’s event include eco-design, real-time monitoring, DC solutions, integration of renewables and coordination between TSOs. There will also be exhibits dealing with smart grids and the Supergrid. A special area will be set aside for poster sessions. ■



Paris in the Spring.

23
“ SEPTEMBER 23–26, 2012
HUSUM, GERMANY
 WindEnergy

The biennial WindEnergy at Husum is one of the most important international wind energy trade fairs. Over 1,200 exhibitors from over 30 nations are registered: wind turbine manufacturers, component suppliers, operators, etc. The conference includes over 75 programmes with some 200 international speakers covering the latest wind energy topics and trends. ■



Brazil welcomes with open arms.

15
“ OCTOBER 15–19, 2012
BALI, INDONESIA
 CEPSI

The Conference of Electrical Power Supply Industry (CEPSI) is the largest electric power conference in Asia. It features keynote speeches, panel discussions, technical presentations and exhibitions and is attended by approximately 2,000 electricity industry representatives. This year’s theme: “Enhancing Clean Technology and Securing Investment for Sustainable Electric Power Industry Development”. ■



A conference in Bali is worth the detour.

5
“ SEPTEMBER 5–6, 2012
SHANGHAI, CHINA
 CICED 2012 (China International Conference on Electricity Distribution)

CICED 2012 will bring together engineers, academicians, managers and regulators specialising in distribution grids from all around the world. “New technology, New Life – Advancing Distribution Grid”: the theme of CICED 2012 continues to explore smart grid opportunities. The conference will also feature an exhibition displaying new products and equipment from leading manufacturers. ■

25
“ SEPTEMBER 25–27, 2012
RIO DE JANEIRO, BRAZIL
 DistribuTECH Brasil

In 2012, DistribuTECH launches the South American version of its Conference & Exhibition in Rio de Janeiro reflecting Brazil’s huge growth opportunities. This electricity transmission and distribution event will focus on such topics as smart metering, distribution automation, energy efficiency, energy losses and long-distance, high voltage electricity transmission. ■

4
“ DECEMBER 4–6, 2012
BIRMINGHAM, UK
 ACDC

ACDC is a long-established international conference on AC and DC power transmission. The conference will address key issues of renewable technologies, environmental, regulatory, political and social factors. Attendees will be able to obtain information on the latest advances in HVDC and HVAC technologies, including FACTS devices, and find out about the most recent AC and DC projects. ■

Grid-Sector-L1 Think...Grid...10-2859-2012_08-EN © ALSTOM 2012. All rights reserved. Information contained in this document is indicative only. No representation or warranty is given or should be relied on that it is complete or correct or will apply to any particular project. This will depend on the technical and commercial circumstances. It is provided without liability and is subject to change without notice. Reproduction, use or disclosure to third parties, without express written authority, is strictly prohibited. Printed on paper made with pure ECF (Elemental Chlorine Free) ecological cellulose produced from trees grown in production forests under responsible management, and selected recycled three-layer fibres.

Alstom Grid
Immeuble Le Galilée
51 esplanade du Général de Gaulle
92907 La Défense Cedex
France

www.alstom.com

ALSTOM