



Christian Teyssandier

In 1962 he joined Merlin Gerin, going on to graduate from the Institut National Polytechnique de Grenoble (INPG) in 1967. Working first on magnetism problems for linear motors until 1974, he then held a variety of positions of technical responsibility in the HV, MV and LV power capacitor field. In 1983 he was appointed project manager for the MV instrument transformer activity. In 1992 he joined the Anticipation section of Merlin Gerin's Medium Voltage Division.

n° 170

from current transformers to hybrid sensors, in HV

glossary

birefringence:

materials with a refraction coefficient depending on propagation direction, polarisation status and light wave frequency, are said to be anisotropic or birefringent.

EMC:

electromagnetic compatibility: this is the capacity of a device to operate correctly in its electromagnetic environment without generating intolerable disturbances for the equipment placed in this environment (see «Cahier Technique» n° 149)

hybrid sensor:

current or voltage sensor comprising at least one element sensitive to the value to be measured, coupled to an electronic system sending a secondary signal (current or voltage), which reflects the module and phase of the primary value.

Remark

Voltage levels enter a variety of classifications according to decrees, standards and other more specific specifications such as those of certain energy distributors, e.g. as regards AC voltages above 1 000 V:

■ French decree of November 14th 1988 defines two voltage ranges:

HVA = $1 \text{ kV} < U \leq 50 \text{ kV}$,

HVB = $U > 50 \text{ kV}$.

■ the CENELEC (European Electrotechnical Standardisation Committee) states in its circular of July 27th 1992:

MV = $1 \text{ kV} < U \leq 35 \text{ kV}$,

HV = $U > 35 \text{ kV}$.

■ publication IEC 71 specifies the highest voltage ranges for equipment:

range A = $1 \text{ kV} < U < 52 \text{ kV}$,

range B = $52 \text{ kV} \leq U < 300 \text{ kV}$,

range C = $U \geq 300 \text{ kV}$.

A revised edition, which keeps only two ranges, is scheduled:

range I = $1 \text{ kV} < U \leq 245 \text{ kV}$,

range II = $U > 245 \text{ kV}$.

■ the French electrical power distributor, EDF, currently uses the classification of the decree quoted above.

from current transformers to hybrid sensors, in HV

content

1. Introduction		p. 4
2. General	Sensor functions	p. 4
	Sensor evolution	p. 5
	The values to be measured	p. 5
	The various types of current sensors	p. 6
	Standardisation	p. 7
3. Current transformers	Use	p. 9
	Standards	p. 9
	Specification of a CT	p. 10
	Special applications	p. 12
	EMC behaviour	p. 13
	A special risk	p. 13
4. Rogowski coil current sensor	Operation	p. 14
	Standards	p. 15
	Steady and transient state operation	p. 15
5. Hybrid sensors	Specification of Rogowski coil current sensors	p. 16
	EMC behaviour	p. 16
	Faraday effect optical sensors	p. 17
6. Comparison table, synthesis	Hall effect current sensors	p. 19
	Zero flux current sensors	p. 20
7. Conclusion and future		p. 21
	Present solutions	p. 22
Appendix 1: CT accuracy as in IEC 185	Future solutions	p. 22
		p. 23
Appendix 2: CT classification as in IEC 44-6		p. 24
Appendix 3: bibliography		p. 24

Technical and technological changes in the protection and control/monitoring equipment used in electrical power distribution networks must be mirrored by parallel changes in their information sources, i.e. in current and voltage sensors.

This «Cahier Technique» mainly deals with current sensors for medium voltage applications.

Following a few reminders on information needs and on current transformers, this document then presents the new hybrid sensors, with particular emphasis on those based on a Rogowski coil. It points out both the advantages and disadvantages of these solutions according to their field of application.

1. introduction

Proper operation and safety of electrical power distribution networks, from the electrical power station right through to the point of use, is ensured by protection and control/monitoring equipment. This equipment requires permanent knowledge of the two fundamental electrical values, namely current I and voltage U.

The knowledge of these values has many angles:

- type of current (AC or DC);

- voltage level (low voltage - LV, high voltage - HVA and HVB-);

- transient evolutions of these values linked to status changes occurring naturally or accidentally in operation of electrical networks.

A number of physical phenomena can be used to measure AC currents.

These methods result in levels of performance which have a varying degree of compatibility with those

required by the various protection, operation and safety levels sought.

Evaluation of sensor performance is vital to ensure their best possible specification for installation on a network. This requires knowledge of how the different types of sensors work.

2. general

sensor functions

Sensors have three main functions:

- providing a correct image, as accurate as possible, of the electrical value to be measured;
- isolating the power networks from the measuring, protection and control/monitoring networks;
- ensuring either interchangeability between the measuring, protection and control/monitoring units or performing one specific function of these units.

Providing a correct and accurate image

Based on the two characteristic values of all electrical networks, i.e. current and voltage, the measuring, protection and control/monitoring equipment defines a certain number of parameters such as: $\cos \varphi$, threshold overshooting, instantaneous power,...

Thus, there are a number of reasons (financial, safety, operating dependability) why the signals sent by the sensors supplying this equipment must be correct and accurate:

- correct

A sensor is correct if it gives, in specified conditions, a signal x_2 which

is identical, in a ratio of a measuring factor, to the one to be measured.

$$x_1 = k x_2$$

where k = measuring factor.

- accurate

A sensor is accurate if the measuring factor k is not dependent on time and usage conditions, provided the latter remain within the specified values:

$$\begin{aligned} \text{if at } t_1 & \quad x_1 = k_1 x_2 \\ \text{and at } t_2 & \quad x_1 = k_2 x_2 \\ \text{and if} & \quad k_1 \neq k_2, \end{aligned}$$

then the measuring sensor is not accurate.

Further on in this «Cahier Technique», examples will be given of sensors which are neither correct nor accurate in certain operating conditions, particularly in transient states, which differ from specified conditions.

The winding ratio, or more generally the measuring factor, is used to adapt the signal to be measured to the performances of the device measuring, analysing and processing this signal.

The measuring, protection and control/monitoring equipment, which uses low level input values, cannot accept the disturbances existing on the power

networks to which they are connected by means of the measuring sensors.

Separating the power network from the measuring, protection and control/monitoring network

Electrical networks are affected by strong electrical and electromagnetic disturbances, particularly severe in high voltage substations. These disturbances are the result of switchgear operations (disconnectors, switches, circuit-breakers and contactors), of the atmospheric discharges to which overhead lines are exposed and of the appearance and disappearance of faults on the operating networks.

These disturbances are locally and temporarily superimposed on rated current and voltage values, thus causing disturbances.

Transmission of these disturbances to the sensor secondary must be compatible with the insulation and input impedance levels of the measuring, protection and control/monitoring equipment. The level of this transmission depends on a galvanic insulation of varying quality between

the sensor primary and secondary circuits. The transmission factor is a function of:

- sensor production technologies;
- and the physical phenomena chosen (to perform the measurement), some of which result in a virtually zero factor.

Galvanic insulation therefore plays a vital role in EMC (Electromagnetic compatibility) behaviour of the various sensor types.

The EMC behaviour of each type of sensor presented in this «Cahier Technique» will be examined.

Behaviour also depends on the associated equipment since sensors are used to adapt the various measuring, protection and control/monitoring equipment to the power network.

Interchangeability and satisfaction of specific functions of the devices «supplied» by the sensors

Measuring, protection and control/monitoring equipment underwent major changes in the nineteen eighties and is still being developed today. As a result, three different technologies can be found in the same electrical switchboard.

■ electromechanical

This is the oldest technology, using the electromagnetic effects of the electrical values. This means that sensors must supply a very high energy, around 15 VA in normal operation and reaching, in certain specific cases, 3 400 VA on occurrence of a fault on the sensor primary circuit.

■ analog electronics

This more recent technology emerged with the intensive development of semiconductors. This equipment requires far less energy, around 1 VA in normal operation and 225 VA on a fault. A number of protection relays can then be connected onto the same sensor output.

■ digital electronics

This microprocessor based technology, which is the most modern, is still being developed. The energy required is very low, around mVA (0.001 VA) in normal operation and 0.25 VA on a fault. Consequently, sensors may generally only have one very low power output sufficient to supply their associated protection and control/monitoring unit.

In certain cases, however, particularly for differential protections (zone, busbar, transformer,.....), sensors must have at least two outputs.

These developments have not yet been fully taken into consideration by sensor standards, thus meaning that full use cannot be made of all the advantages offered by microprocessor technologies and sensors developed in recent years. However, measuring, protection and control/monitoring units benefiting from these developments are available on the market, particularly in HVA and HVB. This equipment is associated with specific sensors ensuring the best match possible between the power network and the control and monitoring unit. These sensors can only be used with the measuring, protection and control/monitoring equipment for which they were designed.

sensor evolution

Besides the fact that modern equipment is less energy consuming, sensor evolution in recent years is above all related to three requirements:

■ reliability

Motivated by permanent search for continuity of service and limitation of external effects in the case of incident.

■ correctness and accuracy

Evolution of network equipment, particularly in HVB with the emergence of gas insulated devices, and search for continuity of service, have resulted in development of linear or linearised sensors. These sensors ensure protection and control/monitoring systems can take efficient action in transient states.

■ cost

Proper network operation to increase continuity of service, requires knowledge of network characteristic values in a large number of points. This results in an increasingly large number of sensors being used. Sensor cost is thus an important factor.

the values to be measured

Voltage level

This is an important characteristic of the network on which the sensors will be installed. This voltage level determines the dielectric stresses used to determine sensor size.

Standard IEC 71 defines the highest voltage for equipment, U_m , as the maximum value of phase to phase voltage that the network can assume.

The power frequency short duration withstand, the impulse voltage withstand, 1.2/50 and, where applicable, switching impulse and broken wave withstand are associated with U_m both in this publication and in publications on measuring sensors.

This publication divides standard U_m values into three ranges:

- range A: from 1 kV to under 52 kV,
- range B: from 52 kV to under 300 kV,
- range C: from 300 kV and over.

The remainder of this «Cahier Technique» chiefly concentrates on sensors for range A networks.

Value types

Management, monitoring, protection and remote control of all electrical network types require use of the two values, voltage and current, characteristic of all electrical circuits.

■ voltage

The rated value of an electrical HVA network varies from a few hundred volts to a few tens of thousand volts. Fault voltages are generally low and often close to zero.

■ current

Rated value varies from a few amperes to a few thousand amperes. Fault currents can reach several tens of kiloamperes.

Only current sensors will be presented in this «Cahier Technique», as they account for the majority of sensors detecting electrical values in networks. Their economic influence is greatest in HVA... and must therefore be minimised.

This requires:

- firstly, knowledge of required performances for the application to deal with and then specify these performances as accurately as possible;
- secondly, knowledge of the operation and evaluation of the performances of the various current sensor types.

Using the values

For network operation, these characteristic values (voltage and current) are used by a variety of equipment. Knowledge of this equipment makes it possible to specify

the characteristics of the current sensor secondary.

■ measuring instruments

□ switchboard indicators: not very accurate, they are used to read the value of the measured values. Note that pointer type display is increasingly being replaced by digital display built into the control and monitoring unit.

These instruments are ammeters, voltmeters, wattmeters, frequency meters, etc... From class 1.5 to 3, their association with a class 1 sensor is generally sufficient for the function to be performed.

□ meters and recorders: used either for billing by energy distributors or for breakdown of power consumption between workshops belonging to the same consumer. Their accuracy is generally greater than the indicators described above. For billing purposes, the associated sensor is generally class 0.5. For power consumption breakdown, the accuracy required is lower, and a class 1 sensor is generally sufficient.

■ protection relays

Of modular type, each element has a clearly defined function. These elements are often combined to monitor a part of the electrical network (see fig. 1). The best known elementary functions are the following protections:

- phase overcurrent (overload or short-circuit),
- zero sequence overcurrent,
- current directional (phase and zero sequence),
- zone differential,
- active reverse power,
- reactive reverse power.

■ protection and control/monitoring units

These are incorporated, configurable microprocessor based units (see fig. 2). These units combine, in the cubicles (level 1 of an electrical network technical management system), in a very small space, the various functions required to operate electrical networks, namely:

- measurements,
- protection devices,
- automatic controls,
- communications to higher levels 2 (substation) or 3 (operating station).

Note that high currents and voltages must be avoided on the input circuits to this equipment. The function of the current and voltage sensors is to adapt signal level to these input circuits (measurement and/or protection).

the various current sensor types

Current sensors fall into three main families:

- transformers,
- specific sensors,
- hybrid sensors.

Current transformer - CT -

This sensor has two electrical circuits, a primary and a secondary, and a magnetic circuit. It supplies a secondary signal of the same type as the primary value to be measured: it is a current source. Although it is not linear and its operating range is limited by magnetic saturation phenomena, it is at present the most commonly used sensor type in HVA and HVB.

A CT may contain several secondaries, each used for a precise function, measurement or protection.

■ «measurement» secondary

It has a very narrow range of accuracy, generally limited to currents equal to or less than the rated primary current.

■ «protection» secondary

Its range of accuracy is very large, often one to twenty times rated primary current. The design of this secondary varies considerably according to the

operating mode, steady state or transient state, for which it is intended. Note that the operating range of a CT is generally far more extensive than its range of accuracy, since it must allow for short-circuit current.

Specific sensor - SS - or Rogowski coil sensor

Rogowski defined the principle of this sensor in 1912. It differs from previous designs by the fact that it contains no ferromagnetic materials, thus ensuring a perfect linearity in a wide current range, a linearity unaffected by the various frequencies present on HVA and HVB networks. This sensor type combined with a load impedance Z of high value ($\approx 10 \text{ k}\Omega$ at 50 Hz) is a voltage source (see fig. 3).

Hybrid sensors - HS -

The definition of a hybrid sensor given in the glossary covers several types of sensors. Only the best known types and those most commonly used in HVA and HVB are described below.

■ optical current sensor

Its sensing element is either an optical fiber or an optical crystal. In both cases, Faraday's principle, discovered in 1845 by the physicist of the same name, is used.

■ zero flux transformers

In this type of HS, the sensing element is a CT in which the flux created by the primary is cancelled for each secondary winding by an auxiliary winding (see fig. 4). This cancels the distortion caused by saturation but only in a



fig. 1: modular type protection relay (Vigirack - Merlin Gerin).



fig. 2: protection and control/monitoring unit (SEPAM 2000 - Merlin Gerin).

limited operating range (current and frequency).

■ **Hall effect current sensor**

Its sensing element is a Hall cell (see fig. 5), which enables both AC and DC currents to be measured. As it generally uses a magnetic circuit to increase its sensing capacity, it is affected by saturation phenomena, just like a CT.

standardization

Existing standards, both national and international, only cover CTs (current transformers). Work is currently in progress to draw up standards for hybrid sensors (HSs). However, there are as yet no plans to deal with specific sensors.

National standards

In the EEC, national standards of the different countries are currently being harmonised by CENELEC on the basis of the international standards edited by the IEC.

International standards

The IEC, via the Technical Committee N° 38 draws up the standards for current and voltage sensors.

Accuracy

On the basis of current CT standards, a certain number of generic terms can be defined for application to all sensor types. In this standard they are referred to as «accuracy» and are used to specify and evaluate the performances and fields of application of current sensors.

■ **theoretical winding ratio**

Ratio between the rated rms values of the primary and secondary values, generally referred to as Kn. For CTs it is a number without dimension. For SSs and HSs it is often expressed in Amperes (primary) /Volts (secondary).

■ **error**

All sensors have imperfections which introduce distortions in the restoration of the secondary signal. There are three error types in AC current:

- **ratio error:** expressed as a percentage, it is calculated from the difference between real and theoretical winding ratios (see appendix 1);
- **phase error:** normally expressed in angular minutes, it gives, to the

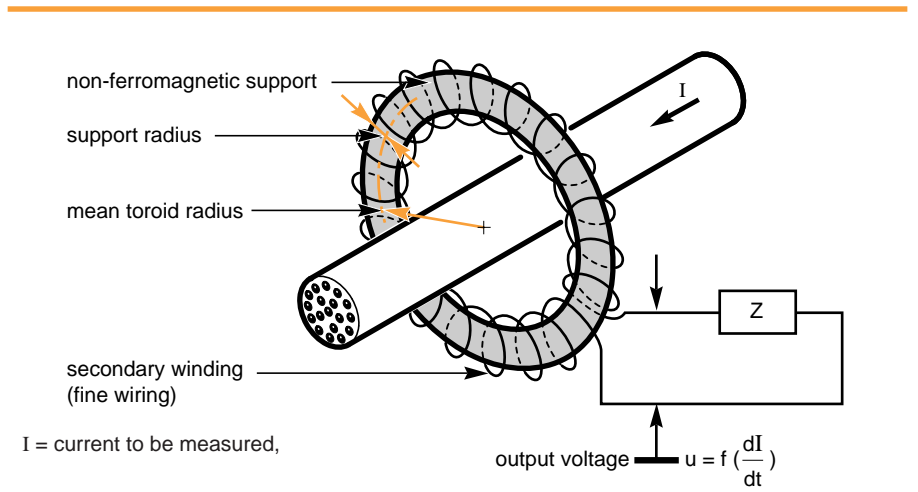

fig. 3: schematic diagram of a SS.

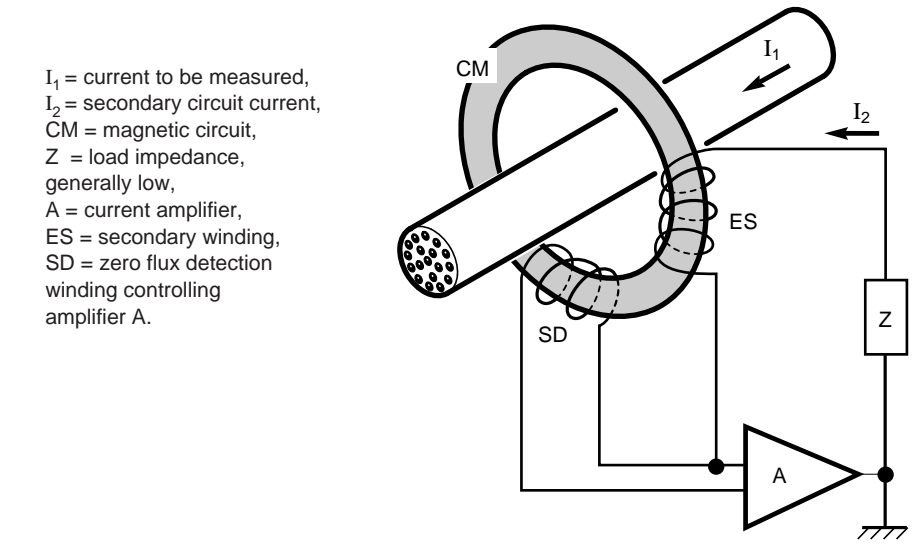

fig. 4: schematic diagram of a zero flux CT.

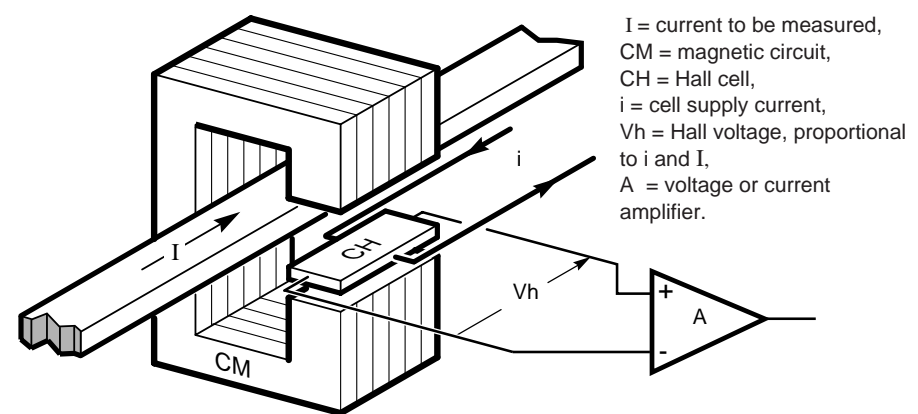

fig. 5: schematic diagram of a Hall effect current sensor.

nearest π (CT) or $\pi/2$ (SS), the phase displacement existing between the vector of the primary value and the vector of the secondary value (see appendix 1);

□ composite error: expressed as a percentage of the rms value of the primary current, in steady state it is the rms value of the difference between:
- the instantaneous value of the primary current,

- and the product of the rated winding ratio by the instantaneous value of the secondary current.

■ accuracy class

The accuracy class defines for current sensors the maximum error limits (ratio and phase errors) in specified conditions.

■ accuracy load

Expressed in ohms, with a specified power factor, it is the value of the

impedance connected to the sensor secondary terminals on which the accuracy conditions are based.

■ accuracy output power

Expressed in VA, it is the apparent power that the sensor can supply at its accuracy load when the rated primary current flows through it.

3. current transformer

Its principle (summarised in chapter 2) gives it properties which, although advantageous, also present problems in some cases for network operation.

A technical description of this current transformer, including its behaviour, is given in detail in «Cahier Technique» N° 164 which deals mainly with the problems relating to operation of electrical installations in steady state.

use

In HVB, emergence of gas insulated metalclad equipment and the search for permanent dynamic stability of networks containing high power generators make it necessary to consider operation when the network changes status (transient state).

Saturation and hysteresis, with no major oversizing of CT magnetic cores, mean that the transient state response of this sensor type is neither correct nor accurate. In general, only at the end of the transient state can a correct response be obtained. This delay, in certain operating and fault cases, is not always compatible with safety of equipment and persons. Sometimes the fault needs to be detected during the first period of the transient state which, in certain network types, can last 200 ms (i.e. 10 periods).

Correctness and accuracy are also necessary in transient states:

- in HVB, for equipment located near high power stations and on busbars of major substations;
- in HVA, near sources, when a high power HVB network is supplied either by a transformer with a high winding ratio (e.g. 220 kV/20 or 36 kV) or by generators with a very high unit power.

Current standards make it possible, for CTs and in both operating cases (steady and transient states), in specified conditions, to accurately evaluate the performances of this equipment.

standards

Steady state

CTs having to operate in this state must meet international, European and national standards.

- international standards
IEC 185, second edition of 1987 currently being revised by CE 38: it concerns class P protection and instrument CTs (see appendix 2).

The main purpose of this revision is to remodel clauses on dielectric characteristics and to add a certain number of measures concerning only CTs for HVB such as mechanical forces on connections, radioelectric interference.

- European standards
These standards, edited by CENELEC, are based on IEC documents. In 1993 there were not yet any EN documents for CTs. Only the harmonisation documents (HD) are under discussion.

- National standards
The different European standards vary considerably from each other. However, in the future they should be more similar since they will be made to conform to the EN standard on CTs for steady state operation.

- France
Standard NF C 42-502 (February 1974) complies with IEC documents in virtually all aspects, and will comply with EN standards completely except for the ways of marking secondary terminals.

Note :

Standard NF C 42-502 states that the secondary terminal connected to the earth is always marked S2. It is also the terminal common to all ratios in the case of CTs with several winding ratios obtained by connections to the secondary winding. Moreover, the same standard states that windings used for measurement must have an odd number and windings used for protection an even number.

- Great Britain
Standard BS 3938 (February 1973) closely resembles the IEC standard and will virtually comply with the EN document. Moreover, it contains the class X windings for protection. This type allows a more accurate specification of protection windings. This class may be included in the EN European standards in the near future.
- Italy
Standard CEI 1008 (October 1987) (Comitato Elettronico Italiano) complies with IEC 185. It will also comply with the EN standard when it is published.
- USA
Standard ANSI/IEEE C57 13 (1978) differs considerably from IEC 185 and European standards:
 - accuracy classes and powers are not defined in the same terms,
 - terminal marking is very different,
 - and the devices frequently take up more space.

Transient state

Major energy distributors have long since possessed company specifications for CT transient state operation.

These specifications were and still are, met by special manufacturing processes and are the subject of direct agreements between manufacturers and users.

- international standards
Specifications concerning CTs for protection, for a transient state response, are now stipulated at international level by standard IEC 44-6 (first edition 1992-03).
- European and national standards
These standards do not yet exist. The European standard, currently being drawn up, will closely resemble IEC 44-6. National standards will be edited by the various organisations on the basis of the EN document.

specification of a CT

The various people involved

The user, the network designer, the protection system manufacturer and the CT manufacturer all have different roles to play, at different levels, in CT specification.

- the network designer, for operating safety reasons, tends to increase the sizing factors linked to the CT primary:
 - short time thermal and dynamic current withstand represented by the root mean square (rms) and peak values of the short-circuit currents to be withstood for a period generally of 1 second.

- length of asymmetrical (unbalanced) state by giving overestimated X/R ratio and time constants.

- the relay manufacturer who, also for equipment operating safety reasons, tends to specify high secondary performances.

- accuracy level power by overestimating the value of the coupled impedances between relay and CT;
- accuracy class by asking the CT not to introduce any additional errors into the unit. Whereas it would perhaps be more advantageous to use slightly more accurate equipment and slightly less accurate CTs to obtain an identical overall accuracy.

Example: a class 3 measuring instrument with a class 0.5 CT gives an overall accuracy of class 3.5. In certain cases, it is more advantageous (financially) to take a class 2 instrument and a class 1 CT which give an overall accuracy of class 3. This is particularly true in the case of small primary currents and a high short-circuit current.

- the CT manufacturer who tries to reconcile the various requirements as well as his own, in order to meet the demand. The I_{th} / I_n ratio (short time thermal withstand 1s / rated primary I) gives a good idea of CT feasibility, irrespective of the secondary performances required. For example:
 - $I_{th} / I_n \leq 100$: the CT obtained can be considered standard with normal secondary performances.
 - $100 < I_{th} / I_n \leq 400$: the CT meeting

this specification is a CT whose feasibility is studied individually: its secondary performances are reduced.

- $I_{th} / I_n > 400$: this CT is not always feasible. When it is, its secondary performances are very poor.

The values to be specified

A number of values must be specified to make a CT. Some of these values are standardised (refer to the standards quoted in the «standards» paragraph). For CTs needing a specified accuracy in the transient state, the reference is either standard IEC 44-6 or company specifications.

The following list only concerns CTs operating in steady state.

■ primary

- insulation level defined by three voltages, the highest network voltage (U_m), the rated time power frequency withstand voltage and the lightning impulse withstand voltage;
- the rated short time thermal current (I_{th}) and its duration if it differs from 1 s;
- the rated dynamic current (I_{dy}) if its peak value differs from $2.5 I_{th}$;
- the rated primary current.

Rules for the profession stipulate that the rated current of the network on which a CT is installed, be between 40 and 100% the rated primary current of the CT.

■ secondary

The function, measurement or protection, of the secondary must be specified and leads to varying constraints and specifications. In both cases, the rated secondary current must be specified (1 or 5 A).

□ measurement

The rated output power (in VA), the accuracy class and the maximum safety factor (SF), normally between 5 and 10 and very exceptionally less than 5, must be specified.

Note: The safety factor is the ratio between the primary current for which the winding ratio error is greater than or equal to 10%, and the rated primary current.

The various accuracy classes and the resulting constraints are given in the standards.

For switchboard devices, class 1 is generally more than enough. This secondary is normally referred to as follows:

10 VA C11 FS < 10

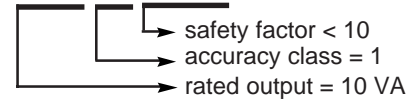

□ protection

The protection windings can be specified in two ways:

- As in IEC 185 and European standards: by specifying the rated output (in VA), the accuracy class (5P or 10P) and the accuracy limit factor (ALF).

The accuracy class gives the maximum composite error allowed on the secondary current for a primary current equal to ALF times the rated primary current (5P = 5%, 10P = 10%). The characteristics and constraints associated with the various accuracy classes are given in the various standards.

The windings are then referred to as follows:

10 VA 5P 10

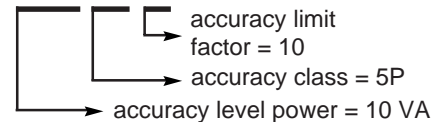

- As in BS 3938: by specifying the value in volts of the knee point voltage (V_k), the maximum winding resistance (R_{ct}) and, if necessary, the maximum exciting current (I_0) for the voltage V_k . In this case, the windings are referred to as follows.

0,050 150 R 0,50

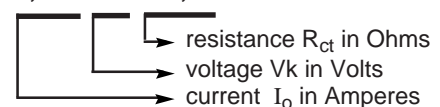

CT imperfections

Magnetic imperfections (saturation, remanence, eddy current and hysteresis losses) generate inaccuracies in the CTs: ratio and phase errors, imperfect linearity,

response depending on previous situations.... Other imperfections are linked to the electromagnetic and electrical environment of the CT.

■ magnetic phenomena

Saturation and hysteresis are the two main causes of disturbance: the output signal of a saturated CT. Output sends a signal which is no longer sinusoidal, and its accuracy can no longer be guaranteed (highly amplified ratio and phase errors).

These phenomena appear:

- in transient state, for example closing of a circuit on a fault with or without DC component: the state of saturation reached depends on the initial magnetic state of the magnetic circuit (degree of residual induction present);
- in short-circuit steady state if the value of this current is greater than ALF times the rated primary current;
- when the value of the load, to which the CT is connected, is greater than its rated burden, as is the case for very long connections or in case of addition of equipment to the load circuit of a secondary winding;
- if network frequency is less than rated frequency: use in 50 Hz of CTs with a rated frequency of 60 Hz causes a 20% induction increase; on the other hand, use in 60 Hz of CTs with a rated frequency of 50 Hz presents no risks.

Operation in saturated state must not be allowed to continue, as saturation causes abnormal overheating the CT components:

- in the magnetic circuit, since eddy current and hysteresis losses increase;
- in the secondary winding, since the currents, although highly deformed, are also very high.

■ external phenomena

□ positions of the primary conductor and of the adjacent conductors
 Their respective geometries and positions may have a considerable effect on the accuracy of instrument transformers as a result of the nonlinearity of the ferromagnetic materials. A typical case is of current transformers installed in a loop (see fig. 6) or installed in staggered form in a busbar (see fig. 7). These two assemblies cause a localised increase

in induction, thus introducing an error.

□ reclosing cycle

After a primary short-circuit current has been broken, return to the remanence value of the induction in the CT magnetic core is not instantaneous.

This induction decreases according to an exponential law with a time constant T_2 . Depending on the secondary circuit, this constant is generally between one and three seconds. When rapid reclosing occurs, a residual induction is

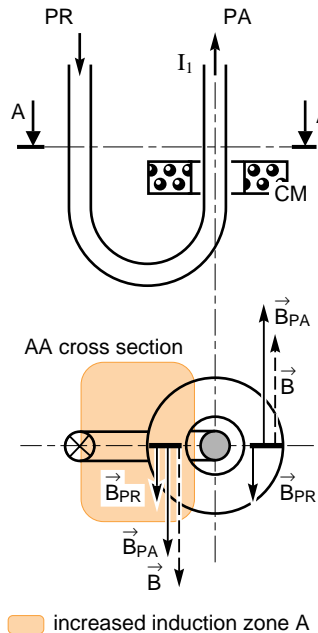

fig. 6: diagram showing a transverse CT with a looped primary circuit.

The return or adjacent phase conductor (PR) creates a disturbing magnetic field in the magnetic circuit (CM); this field is vectorially added to the one created by the current I_1 to be measured of the conductor crossing it normally (PA). This vectorial addition results in increased induction in zone A. This induction increase depends on:

- the current flowing in the disturbing conductor,
- the distance between the magnetic circuit and this disturbing current.

It then results in local saturations which increase the value of the exciting current (I_e), thus introducing errors.

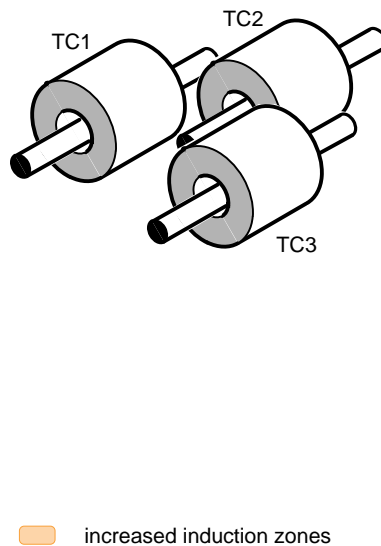

fig. 7: diagram showing three transverse CTs installed in staggered form in a busbar

therefore present in the CT magnetic circuit which is vectorially added to the induction created by the current being formed (see fig. 8). If both inductions have the same sign and if the CT has not been designed to guarantee a given accuracy in the transient state, it is highly likely that the secondary signal delivered by this CT will be totally unlike the primary current flowing through it.

■ precautions to be taken with CTs

□ in steady state:

- CTs must be designed for their intended purpose.

- the sum of the input impedances of all the relays and/or measuring instruments, to which the value of the wiring impedance must be added, must be less than or at the most equal to rated burden. This impedance is obtained by dividing the rated output by the square of the rated secondary current.

- installation conditions should not cause high local saturation. It shall be doing away with staggered installations (see fig. 7)

□ in transient state, for protection secondaries only

- in the general case of constant time protections, to allow for all or part of the hysteresis phenomena, it is sufficient to check that the value of the intervention setting current (of the protection) divided by the value of the CT rated secondary current, is less by twice the accuracy limit factor of the secondary in question.

- for time dependent protection devices (differential, zero sequence,...), ensure that the CT specification complies with the recommendations of the relay manufacturer

- if an accurate response is required during this operating period, CTs must be specified and designed in accordance with the various classes defined in IEC 44-6 (see appendix 1). This standard always leads to considerable oversizing of the CTs. The need for a low remanent flux (case of reclosings) results in use of magnetic circuit with airgap. This is how the linearised CTs are obtained (see TPZ in standard IEC 44-6).

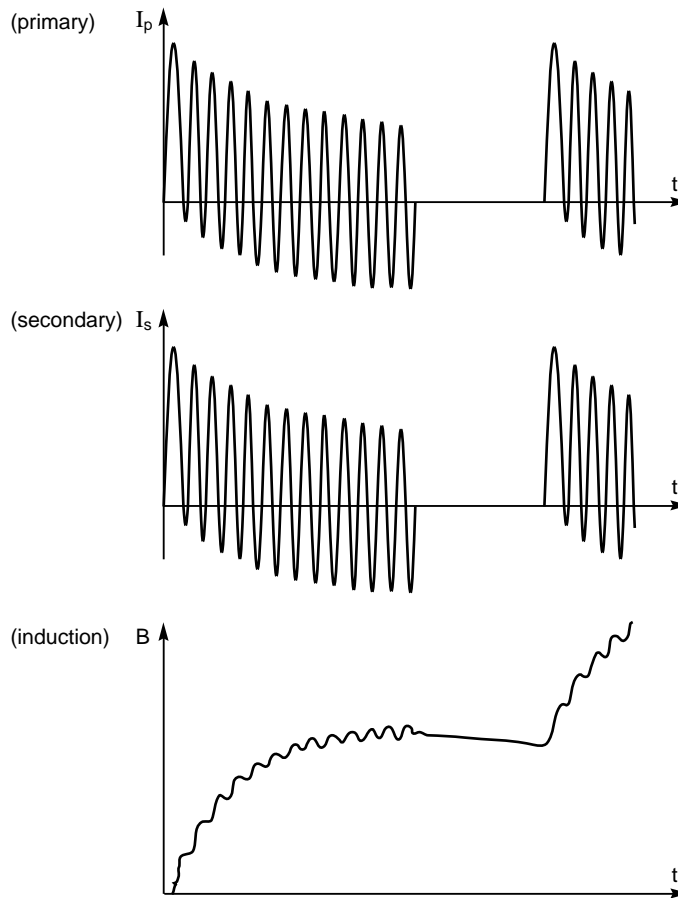

fig. 8: evolution of currents and induction in an unsaturated CT.

special applications

Measurement of residual currents

Protection of persons in LV distribution networks is frequently ensured by monitoring residual current value. This protection, generally provided by a device incorporated in the LV circuit-breaker, is often autonomous: its operating energy is supplied by the CT detecting the residual currents. Stipulated CT performances generally call for use of ferromagnetic materials with excellent relative permeability (μ_r) using nickel, which raises their cost. There is a quick method of sizing this CT type (see appendix 3, bibliography: paper in the RGE review n° 4).

Measurement of zero sequence current (I_0)

This is the current resulting from the vectorial sum of the three phase currents of a three-phase circuit. This sum can be achieved in two ways.

■ by adding up the secondary currents of three CTs (Nicholson assembly).

For this, CTs with the same winding ratio must be used, and the primary and secondary connections must respect the polarities (winding direction) of the various primary and secondary windings (see fig. 9).

Two phenomena limit the detection thresholds in this method:

□ in steady state, the differences in

phase and winding ratio error mean that the vectorial sum is not zero. This results in a «false zero sequence current» which may not be compatible with the required thresholds.

Pairing of CTs (in phase and module) enables practical thresholds to be lowered:

□ in transient state, saturation and hysteresis of magnetic circuits generate the same fault. Oversizing of the CTs delays the moment of appearance of this phenomenon.

These solutions (pairing and oversizing) do not generally allow detection of a current I_0 less than 6% of the phase currents.

■ by adding up the fluxes

To avoid the inaccuracy of this first method and find a way round its constraints, the I_0 currents can be measured using a single toroid CT or «toroid»: the three phase currents I_1 , I_2 , I_3 of the three-phase network (see fig. 10) flow through its magnetic circuit. With a suitable design (ferromagnetic material, dimension and accuracy load) and taking certain toroid installation precautions (grouping and centering of cables, use of a ferromagnetic sleeve if necessary), this method enables measurement of very low I_0 current values with a high degree of accuracy (module error around 1% and phase error less than 60 angular minutes): a few hundred mA in HVA and a dozen mA in LV.

■ fault detection

In HVA distribution networks, use of fault detectors facilitates rapid fault location, thus minimising the part of the network not supplied and reducing outage time.

There are two possible means of signalling the fault current detected by these devices:

□ using mechanical or electrical indicator lights placed at points easy to reach by operating staff (case of MV/LV substations in underground rural and urban networks).

□ by remote transmission to the operating centre for fault detectors placed on remote-controlled switches of public distribution networks.

These fault detectors are supplied by CTs for which no standards exist. Only the CT-fault detector combinations are specified by operators.

EMC behaviour

In HVA, the EMC of the CTs can be said to be satisfactory.

In HVB the mandatory electric field distribution shields of varying quality may result in unsatisfactory EMC of CTs.

The coupling capacity between the primary and secondary CT windings helps transmit disturbances from the primary to the secondary circuit. The value of this capacity depends on the CT insulating voltage, the secondary characteristics and the insulation technology used.

Some company specifications, for voltages $U_m > 123$ kV, give a maximum value for the disturbance transmission factor. This value is measured in a standard test described in the specification. The introduction of this notion into international standards is currently being discussed within CE 38.

a special risk

Opening the secondary circuit of a CT is dangerous.

The magnetic induction flux flowing in the magnetic core is the sum of two fluxes of opposite signs, one due to the presence of a primary current and the other to the presence of the secondary current. Cancellation of the latter by opening the secondary circuit considerably increases flux in the core, causing a very high voltage rise at the secondary terminals. Peak or instantaneous voltages of over 5 kV can be reached which may be fatal for persons and cause severe equipment damage.

Practical conclusions

■ on no account must the secondary circuit of a current transformer in operation be opened.

■ before carrying out interventions on the load of a CT in operation, a very high quality short-circuit must be installed between its secondary terminals.

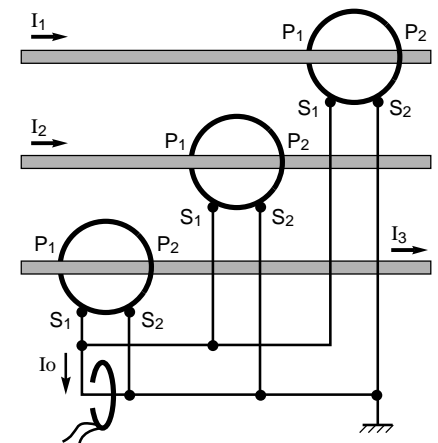
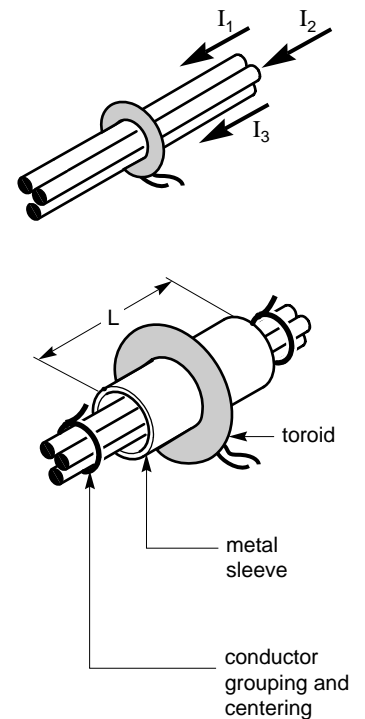

fig. 9: connection of three CTs to measure zero sequence current (Nicholson assembly).



sleeve $L \geq 2\phi$ toroid

fig. 10: measuring current using a toroid.

4. Rogowski coil current sensor

The principle of this current sensor was defined by ROGOWSKI in 1912. From 1986 onwards this sensor, referred to as «SS» (specific sensor), has been developed in industry for HVA networks.

operation

Physical principle

Application of Ampere's theorem to a Rogowski coil (see fig. 3) shows that the voltage appearing at the terminals of a load Z of very high value is a function of the current $I = i(t)$.

The current I to be measured creates locally, at each turn, an induction $b = \mu_0 h$, where μ_0 is the permeability of vacuum, the winding support not being made with a ferromagnetic material, and h the magnetic field corresponding to current I. The flux encompassed by the entire sensor is written as:

$$\phi = \sum_{\text{turns}} \pi r^2 b$$

If all the N turns have identical cross sections and if their centres are placed on the same circle of diameter R which can be considered as very large compared with their own radius r, the following can be written:

$$\phi = N \pi r^2 \mu_0 h$$

and by application of Ampere's theorem:

$$\phi = N \pi r^2 \mu_0 \frac{i(t)}{2 \pi R}$$

The electromotive force developed in the winding is written as:

$$e(t) = - \frac{d\phi}{dt} = - \left(\frac{N r^2 \mu_0}{2 R} \right) \left(\frac{di}{dt} \right)$$

If $i(t) = I \sqrt{2} \sin(\omega t + \varphi)$ thus

$$\frac{di}{dt} = \omega I \sqrt{2} \cos(\omega t + \varphi)$$

and

$$e(t) = - \left(\frac{N r^2 \mu_0}{2 R} \right) \omega I \sqrt{2} \cos(\omega t + \varphi)$$

$$= -K \omega I \sqrt{2} \cos(\omega t + \varphi)$$

Electromagnetic components

A SS sensor is made up of five parts (see fig. 11).

- a primary winding consisting of a single copper conductor, the cross section of which is determined by:
 - a primary rated continuous thermal current,
 - a rated short-time thermal current;
- a secondary winding support generally toric and made of a non-ferromagnetic material;
- a secondary winding support generally toric and made of a non-ferromagnetic material;
- a setting resistance connected to the secondary winding;
- a magnetic shielding protecting the winding from any disturbances linked to the magnetic fields outside the sensor.

Dielectric components

Just like current transformers, the primary and secondary of SS sensors are insulated from each other by a solid dielectric resin in HVA.

■ dielectric shield

In order to improve the system's EMC behaviour, an earthed dielectric shield is placed between the primary and the secondary winding.

Modelling

It is useful to design and use a model to study SS operation, in the same way as for CTs.

The model proposed below only applies to standard frequencies. For high frequencies (several hundred kHz), the distributed capacitances of the secondary winding must be introduced as well as the various primary-secondary, primary-frame and secondary-frame coupling capacities.

Equivalent diagram

Two equivalent diagrams can be drawn up:

- the first one (see fig. 12) is derived from the CT diagram by the presence of an ideal transformer, where:
 - L = inductance value of the wiring connecting the sensor to its load M,

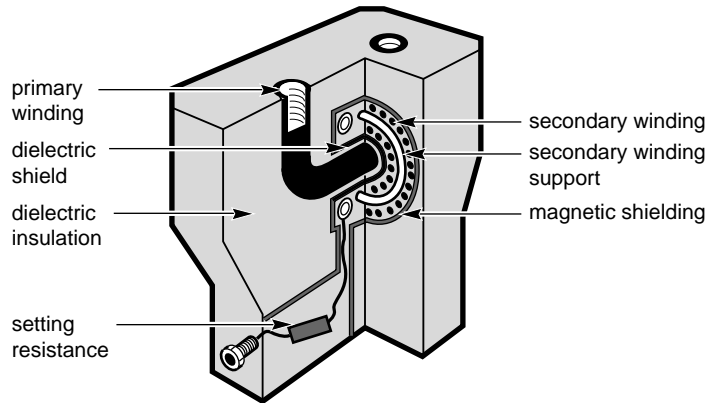

fig. 11: cross section of a SS sensor for HVA.

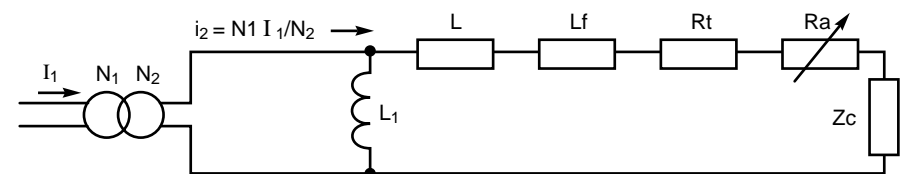

fig. 12: equivalent CT type diagram of a SS sensor.

- L_f is the winding leakage inductance. The secondary winding of the SS sensors has touching turns with excellent distribution on the support. Its leakage inductance is very low and need not thus be considered.
- $L_1 \omega$ = magnetising impedance of the equivalent current generator,
- R_t = sum of the resistances of the winding and connection,
- R_a = setting resistance,
- Z_c = impedance of load M at the considered frequency.

■ the second diagram (see fig. 13) includes a voltage generator derived from the theoretical study. This is the diagram that will be used hereafter.

In this equivalent diagram:

$$E_0(t) = -K \omega I \sqrt{2} \cos(\omega t + \varphi)$$

□ $E_0(t)$ is a source of voltage proportional to the primary current. It has a $\pi/2$ lagging phase displacement with respect to current $i(t)$ where

$$K = \frac{N r^2 \mu_0}{2 R}, \text{ where}$$

□ the product $K \omega$ represents the transformation ratio and is expressed in Volt per Ampere (V/A).

standards

No national or international standards currently define this type of sensor. Consequently SS sensors on the market today comply with the IEC 185 standard, except for the parameters concerning the secondary signal supplying very specific protection and control/monitoring units. These units with their microprocessor technology, enable, by simple parameterisation, via a keyboard or display, all the functions (protection, measurement, automation and communication) to be performed adapted to each installation.

Note:

Today these SS sensors and protection and control/monitoring units, SEPAM, are designed and marketed by one manufacturer only (Merlin Gerin).

steady and transient state operation

As SS sensors have no magnetic circuit they are not subjected to saturation or

residual flux. Their perfect linearity means they give at the secondary an almost perfect image of steady and transient states of the primary.

Manufacturing tolerances on winding support dimensions and on the value of the number of turns (several thousands) are compensated for by a setting resistance (R_a).

Equations

The vectorial diagram (see fig. 14) is drawn up from the equivalent diagram in figure 13. This diagram yields the following equations:

$$U(t) = E_0(t) - (R_a + R_t + jL \omega) i_2(t)$$

avec $i_2(t) = U(t) / Z_c$

Error analysis

■ ratio and phase error

The perfect image of the primary current for a SS sensor is the vector E with a lagging phase displacement of $\pi/2$ with respect to current I_1 , i.e. in phase with E_0 in figure 15. The module of this vector is given by $E = K_1 I_1$, where K_1 is the constant representing the transformation ratio at a given frequency.

In the same way as for all sensors, the secondary signal of the SS sensors has an error. This error is defined as the vector representing the differences of vectors E and U : it is vector $\epsilon_{(nat)}$ on the diagram in figure 15.

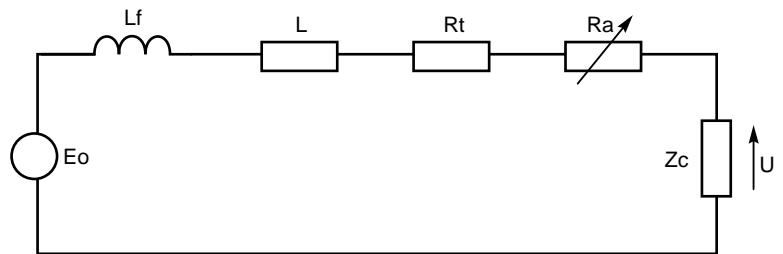

fig. 13: equivalent diagram with voltage generator of a SS sensor.

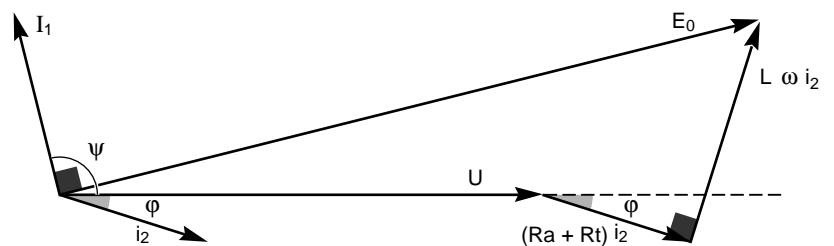

fig. 14: vectorial diagram of a SS sensor.

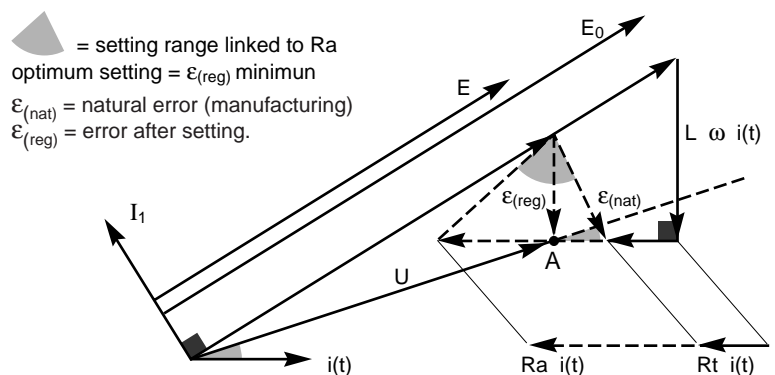

fig. 15: vectorial diagram, with error, of the SS sensor.

At the end of manufacturing it is minimised by setting potentiometer Ra to a value giving a minimum error $\vec{\epsilon}_{(reg)}$ vector. This sensor setting is adapted to the current inputs of the protection and control/monitoring units for which it was designed. The maximum value of this error vector was set at 1% of the value of the reference vector for all primary currents between 0.2 and 10 times the rated primary current, and at 5% for a current 200 times the rated primary current.

With these maximum errors, SS sensors with the same winding ratio are all completely interchangeable and are virtually identical in accuracy terms (see fig. 16) to CTs of class:

- 0.5 for measurement,
- 5P for protection.

■ **linearity**

The SS sensor is linear:

$$e(t) = K \omega I \sqrt{2} \cos(\omega t + \varnothing)$$

This linearity gives it many advantages, the main ones being:

- the possibility of reducing winding ratio variety and thus of increasing standardisation potential. Winding ratios are imposed by the electronics dynamics of the control and monitoring unit with which the sensor is associated and by its required discrimination level.
- an excellent response in transient state. Absence of saturation, hysteresis and residual flux means these sensors respond perfectly in the transient state. Consequently, with no special precautions, this sensor type is installed on networks where protection devices need to take rapid action during transient states, and in particular on networks with long time constant or containing gas insulated metalclad equipment (with a risk of explosion).

External influences

The response of these SS sensors, like that of CTs, may be affected by the environment in certain conditions.

- **modification of the secondary load of this sensor type causes an error variation. To reduce these variations, as a SS is a voltage source, its purely resistive load must be as high as possible ($\geq 10 \text{ k}\Omega$).**

■ **frequency**

The signal sent by this sensor type depends on the primary current derivative (see the paragraph on «physical principle»). Freedom from the effects of frequency is obtained by processing the SS sensor signal by an accuracy integrator amplifier.

■ **primary conductor position**

Ampere's theorem makes no reference to the relative position of the current (primary conductor) and of the closed contour (secondary winding) to which it is applied. This remark indicates that the sensor is theoretically unaffected by the relative positioning of its components. However, imperfections in making of the secondary winding may make it slightly sensitive. Therefore, when installing sensors with non-integrated primary (LV), fairly precise relative centering and azimuthing between primary and secondary must be performed. If this precaution is not taken, errors of around 3% may occur.

■ **adjacent conductor position**

An adjacent conductor, through which the current from another phase or return for a loop (see fig. 6) flows, produces a magnetic field which is vectorially added to the one created by the current to be measured, thus modifying sensor response. SS sensors must be protected against this type of disturbance.

specification of Rogowski coil current sensors

SS sensors and protection and control/monitoring units are supplied by the same manufacturer, thus making SS specification far simpler for the end-user who does not have to specify, as for the CTs, the characteristics of the secondary (secondary current, accuracy level power, accuracy class and accuracy limit factor). He only has to specify:

- the insulation level of the sensor defined as for a CT;
- the rated thermal short-circuit current (I_{th}) and the dynamic current (I_{dyn}) established according to the same rules as for the CTs;
- the operating range (rated primary current and rated continuous thermal current). For example, there are four operating ranges (30-300, 160-630, 160-1600, 500-2500 A) for the SS sensors produced by Merlin Gerin.

EMC behaviour

SS sensors have a small primary - secondary link capacity ($\approx 20 \text{ pF}$ in HVA). The presence of dielectric and magnetic shields, connected to earth, prevents transmission of conducted (from MV primary network) and radiated disturbances. The SS sensor and protection and control/monitoring unit thus has good EMC behaviour.

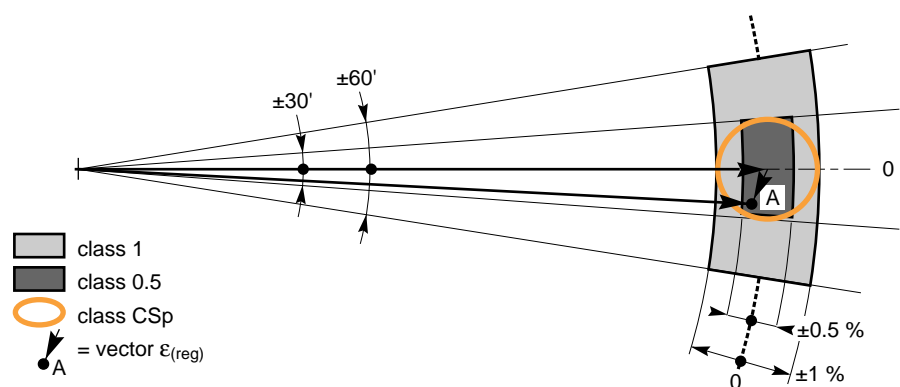

fig. 16: comparison of accuracy of CT and SS sensors
Point A positions the operation of a SS sensor which meets the accuracy requirements of CTs of class 0.5 and of class 1.

5. hybrid sensors

The output signals of the CTs and SSs are directly used by the protection and control/monitoring units. However, the signals of certain other current sensors must be processed electronically before they can be used by these units: these are the hybrid sensors. Their diagram resembles the one in figure 17.

Diagram

It may contain up to six elements:

- **primary sensing element**
Uses the various effects (optical, electronic or electrical) of the materials subjected to a magnetic field created by the current to be measured.
- **primary converter**
Converts the effect used by the sensing element into a signal depending on the primary current and adapted to the transmission system.
- **transmission system**
Conveys the signal transmitted by the primary converter over a distance of varying length.
- **secondary converter**
Converts this signal, representing the primary current, into an electrical signal which can be used by the protection and control/monitoring units.
- **primary supply**
Supplies necessary energy to the sensing element, the primary converter and, if necessary, the transmission system.
- **secondary supply**
Supplies energy to the secondary

converter and, if necessary, to the transmission system.

In certain sensors, these two supplies, primary and secondary, may be the same.

The sensing elements

Hybrid sensors have undergone major developments in the course of recent years. A number of magnetic field effects have been used in primary sensing elements, in particular:

- **optical effects**
Use of the effects of the magnetic field on the properties of light (optical current sensor). Optics may also be used solely as a transmission system from a primary sensing element of any type. Transmission then takes place by optical fibre. The use of devices obeying the laws of light physics (sensing element and transmission system) gives the sensor its perfect galvanic insulation. This advantage has been made use of in many development programmes, some of which resulted in the Faraday effect current sensor.
- **electronic effects**
Influence of a magnetic field on a semiconductor (Hall effect current sensor) and on a ferromagnetic material (resistivity variation used in magneto-resistant current sensors).
- **electrical effects**
The flux created in a magnetic circuit by the magnetic field coming from the

current to be measured, is cancelled by a magnetic flux generated and regulated by means of an auxiliary current (zero flux current transformer).

Faraday effect optical sensors

The laws of light physics will be briefly reviewed below to help understanding of the following sections.

Reminders

- **polarisation**
A phenomenon specific to wave propagation, in particular light waves, characterised by their vibration direction in a given plane, known as the propagation plane, containing the propagation direction. When this plane keeps a direction set in time, the light waves have a linear polarisation. If the plane rotates around the propagation direction at constant speed, polarisation is elliptical or, in a very specific case, circular.
- **birefringence**
Certain natural bodies exhibit the phenomenon of birefringence. A flat light passing through them is not propagated at the same speed according to whether its polarisation plane is parallel to one or the other of the two perpendicular directions specific to the birefringent body. Birefringence may be intrinsic (anisotropic materials) or induced by a stress:
 - mechanical stress or photo-elastic effect,
 - electrical stress or Kerr or Pockels electro-optical effect,
 - magnetic stress or Faraday magneto-optical effect.

Faraday effect

In 1845 Michael Faraday discovered that the polarisation plane of polarised light rotates as it passes through a piece of glass placed in a strong magnetic field and propagated parallel to this field. The polarisation rotation angle (F) is proportional to the

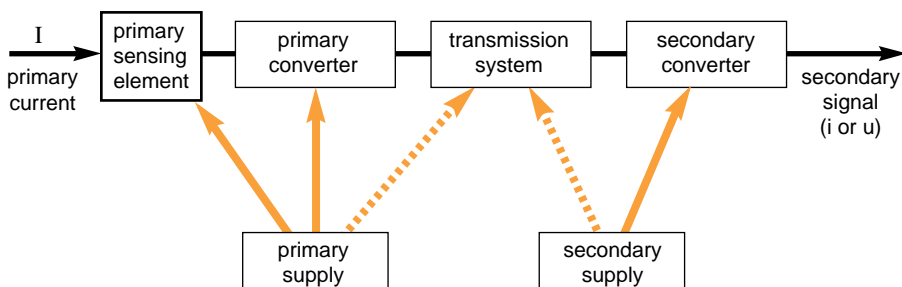

fig. 17: hybrid sensor diagram.

circulation of the magnetic field (H) along the optical path L (see fig. 18).

$$F = V \int H dL$$

In this equation, V is a characteristic of the optical medium, known as Verdet's constant. Generally small, it has a varying dependence on temperature. As the Faraday effect is divergent, a monochromatic light (with single frequency) must be used.

In practice

This effect is used with optical crystals or fibres. In both cases a light source is required and the optical information must be processed so that it can be used by the protection and control/monitoring units.

■ light source

Frequently a monomode laser diode with a wavelength approaching 780 nanometres: Verdet's constant is greatest in this part of the wavelength spectrum.

■ optical crystal

One or more crystals can be used, surrounding to a greater or lesser extent the conductor in which the current to be measured flows (see fig. 19a). In free field optical configuration, which is the most frequent case with crystals, mechanical-optical alignment problems are particularly great.

■ optical fibre

The controlled optics technique uses as a sensing element a monomode optical fibre which can be wound several times around the primary conductor (see fig. 19b). In this case application of Ampere's theorem gives:

$$F = V N I$$

This technique ensures increased sensitivity.

Optical fiber sensors are not sensitive to external currents (return conductor, other phases, other circuits), whereas optical crystal sensors are, to a greater or lesser extent, depending on their construction technology.

On the other hand, the optical characteristics of the sensing element (crystal or fibre) are particularly affected by variations in temperature and mechanical stresses.

■ converting the optical signal into an electrical signal. This is achieved by comparing the light beams emitted and received, generally using polarising-

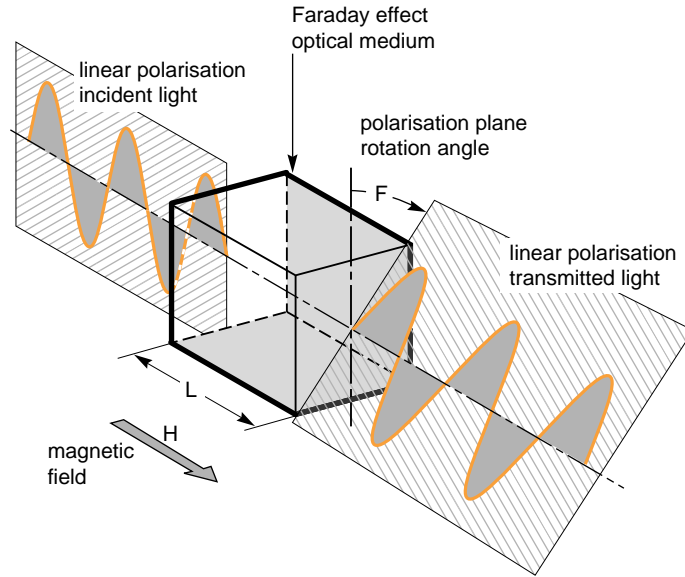
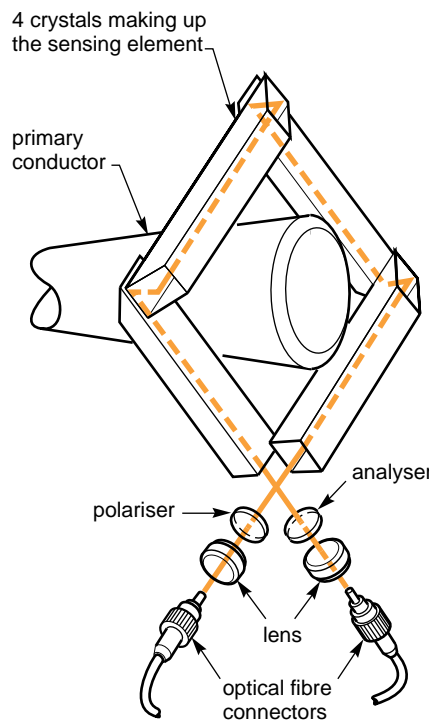
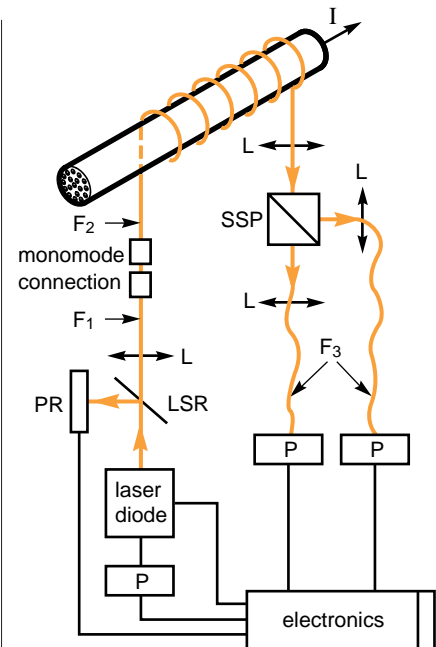

fig. 18: graphic representation of the Faraday effect.

a - exploded view of an optical crystal sensor



b - diagram of an optical fibre sensor



- LSR semi-reflecting blade
- L Selfoc lenses
- F1 polarisation hold optical fibre
- F2 sensor fibre
- F3 multimode optical fibres
- I current to be measured
- SSP separating/polarising system at 45°
- P photodiodes
- PR reference photodiodes

fig. 19 : Faraday effect current sensors.



a - in HVA (Merlin Gerin), with:
 ■ in the foreground an optical sensor with its wound-on optical fibre conductor,
 ■ in the background an equivalent conventional, but more space-consuming, CT sensor.

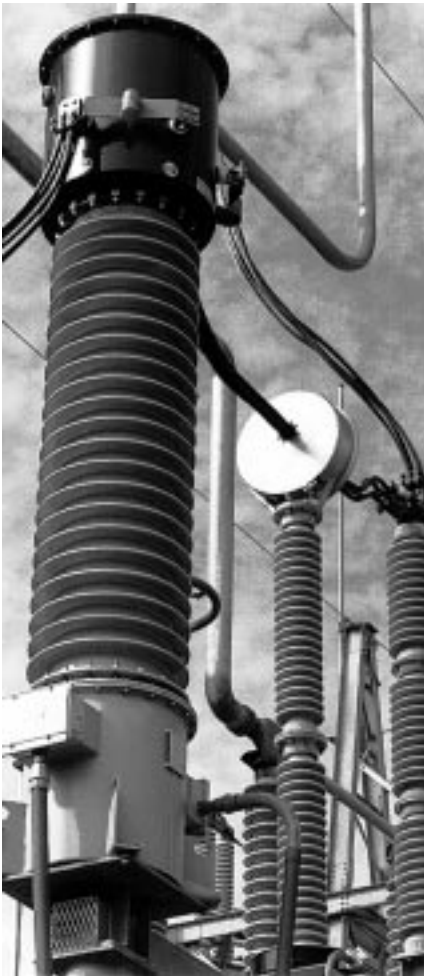

b - in HVB (Square D), with:
 ■ in the foreground a conventional CT,
 ■ in the background an equivalent, but less space-consuming, optical sensor.

fig. 20: optical sensor examples.

separating prisms combined with photodiodes which convert the light signal into an analog electrical signal. The latter is then processed and amplified so that it can be used by the protection and control/monitoring units.

Accuracy

Optical sensors (fibre or crystal) are sensitive to external conditions (temperature, auxiliary energy source), which thus affects their accuracy.

- influence of temperature
 Temperature affects three parameters:
 - Verdet's constant V
 - the birefringence of the optical medium,
 - the wavelength of the light emitted by the laser diode.

In order to operate in the conditions encountered on electrical networks, optical sensors must be temperature compensated (see appendix 3, [5]). Compensation can take the form of:

- permanent action on the optical sensing element (double twist of the fibre, return journey of light through the fibre, thermal compensation of crystal, etc...),
- keeping the laser diode at a temperature compatible with the required accuracy,
- allowing for the real temperature of each element in the output signal shaping line.

- influence of mechanical constraints.
 The crystal or optical fibre must have a very low birefringence rate so as not to alter light polarisation in the absence of magnetic field. Mechanical stresses on the crystal or fibre, linked to temperature variations, implementation and operation, must not change this birefringence rate.

- influence of signal conversion electronics. The crystal and optical fibre

are perfectly linear. However, the processing electronics is limited in its dynamics, for a given accuracy, by:

- its pass-band;
- its ability to detect to a 2π the rotation angle of the polarisation plane.

However, digital signal processing techniques can be used to correct this;

- the supply voltages of the components making up the primary and secondary converter(s).

Despite these problems, present-day techniques can produce optical current sensors of an accuracy comparable to those of CTs (see fig. 20).

EMC behaviour

Since galvanic insulation between the circuits (primary and secondary) is perfect (no coupling capacity), the EMC behaviour (conducted disturbances) of this sensor is good.

However, this behaviour may be affected by that of its primary and secondary converters sensitive to radiated disturbances (shieldings, relative positioning, etc...).

Note that this perfect galvanic insulation is, as regards safety, a major asset for this sensor type in that it does away with the explosion risks existing in HVB with oil insulated CTs.

Hall effect current sensors

Hall effect

A semiconductive wafer through which a current i flows, immersed in a magnetic induction field \vec{B} , develops between two sides a potential difference known as Hall's voltage V_H meeting the equation:

$$V_H = K i B$$

where K is the sensor's coefficient of sensitivity.

This wafer forms the sensing element of the Hall effect current sensor.

Principle

The Hall effect assumes that in a long wafer (see fig. 21), fitted with wide electrodes injecting current i , all the electrons move uniformly at speed V in the opposite direction to current i . When a magnetic induction field \vec{B} is applied perpendicularly to one of the large sides of the wafer, the $-e$ charged electrons are deflected to one of the

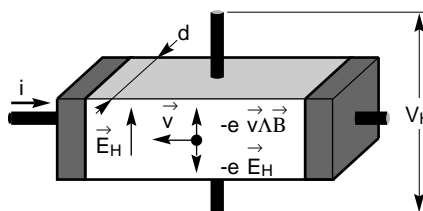

fig. 21: theoretical diagram of the Hall effect sensor.

small sides where they accumulate due to the effect of Laplace's law force.

$$\vec{F} = -e \vec{V} \wedge \vec{B}$$

The load unbalance between the two small sides causes a Hall electric field, \vec{E}_H , to appear, which grows until the force ($-e\vec{E}_H$) balances that of the induction field.

In these conditions, the electrons resume a uniform movement, and Hall's electric field is written as:

$$\vec{E}_H = -\vec{B} \vec{j} / (Ne)$$

where N is the number of charge carriers (-e) and \vec{j} the current density in the wafer: this results in Hall's voltage:

$$\vec{V}_H = K \vec{i} \vec{B} / (Ne d)$$

In practice

A practical solution for increasing sensor sensitivity is to increase \vec{B} . This is achieved by placing the Hall generator in the airgap of a magnetic core through which the induction flux flows due to the magnetic field created by the current to be measured (see fig. 5). Current is supplied and the signal processed by means of electronic elements.

Accuracy

The response of Hall effect sensors is not exactly proportional to B. This is due to three factors:

- offset voltage,
- linearity error,
- fluctuation with temperature.

■ offset voltage

An error voltage linked to the production of the sensing element. For a given temperature range it can be corrected by the secondary converter.

■ linearity error

Presence of a magnetic circuit, even with a relatively high airgap, introduces a nonlinearity resulting from the saturation phenomena. This sensor's dynamics depends on the sizing of the magnetic circuit.

■ fluctuation with temperature

Temperature influences in two ways:

- by the coefficient of sensitivity K which varies by roughly 0.01 % per °C,
- by the mechanical constraints, further to temperature variations undergone by the sensing element.

Sensor production must allow for all these influencing factors and aim to compensate them in order to obtain and

guarantee, in specified conditions of use, an accuracy compatible with the intended purpose (measurement or protection or both). This results in the functional electronics diagram necessary for proper operation of this sensor (see fig. 22).

The pass-band of these sensors is relatively large and it is possible to measure DC currents and currents with frequencies of around 40 kHz. Pass-band width, for this sensor type, depends on the technology of the magnetic circuit, the electronic components and the architecture used for signal processing.

EMC behaviour

Absence of galvanic insulation between the sensor and the electronic elements is a major handicap, particularly in HV. The EMC of the assembly (Hall effect sensor, protection and control/monitoring unit) may thus not be perfect.

zero flux current sensor

Principle

The sensing element is a magnetic circuit (CM) (see fig. 4) in which the flux created by the current to be measured (I_1) is cancelled by a current (I_2). The value of this current is adjusted automatically by an electronic power

amplifier (A) controlled by probe (SD) voltage proportional to the flux flowing in the magnetic core (MC). The resulting flux in this core is zero and the following can thus be written:

$$I_2 = N_1 I_1 / N_2, \text{ where}$$

N_1 = number of primary winding turns,

N_2 = number of secondary winding turns.

Accuracy

This system has an excellent accuracy. Current transformer error measuring benches make use of this principle. The module error can be limited to very small values ($\approx 0.02\%$), as can also be the phase error which may be less than 0.1 angular minute (but which depends on the flux cancellation electronic circuits).

This sensor's performances mainly depend on the performances of the amplifier, both as regards measuring range and accuracy.

Note:

Zero flux current transformers are used to measure DC currents.

EMC behaviour

The signal for cancelling flux approaching zero is easily disturbed. This CT type must therefore be placed in a highly protected electromagnetic environment (shields, filtered supplies, etc...).

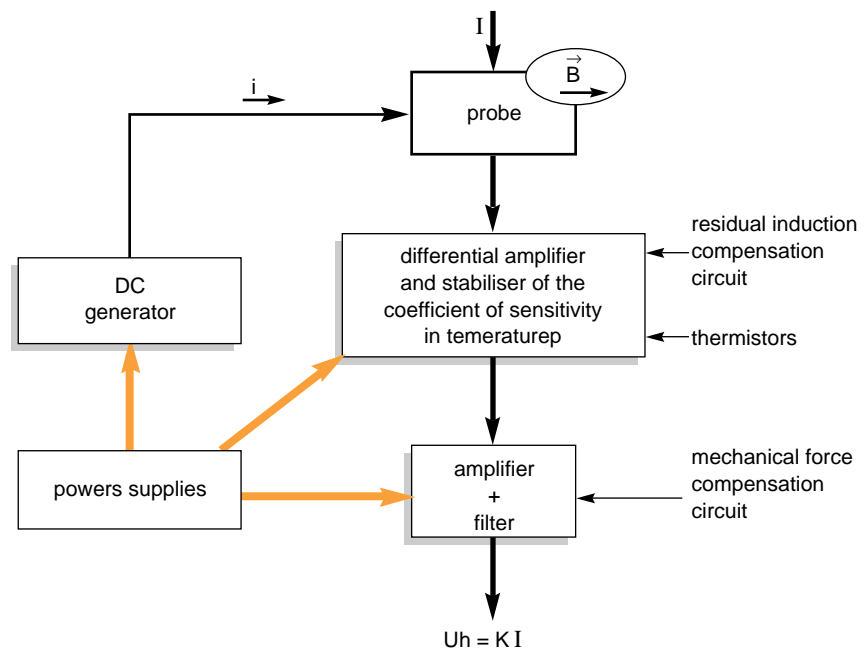

fig. 22: functional diagram of the electronics of a Hall effect sensor.

6. comparison table, synthesis

■ poor ■■ average ■■■ good ■■■■ very good	CT conventional current transformer	SS Rogowski coil sensor	optical sensors	zero flux current transformer
performances:				
■ linearity	■	■■■■	■■■■	■■■
■ exactness	■	■■■■	■■■	■■■
■ dynamics	■	■■■■	■■■■	■■
■ accuracy	■■■	■■■	■■■	■■■■
■ EMC	■■■	■■■	■■■■	■■
capacities:				
■ measuring standard	■■	■■	■■	■■■■
■ supplying energy to protection and control/monitoring units	■■■■	■	■	■■
■ supplying the measuring signal to:				
□ analog energy meters	■■■■	■	■	■
□ digital energy meters	■■■■	■■■	■■	■
□ digital protection and control/ monitoring units	■■■■	■■■■	■■	■
relative cost compared with switchgear:				
■ in HVA	■■■	■■■■	■■	■
■ in HVB	■■	■■■	■■■	■
number of sensors installed each year:				
■ present situation	■■■■	■■■	■	■
■ foreseeable evolution	■■■	■■■	■■	■

7. conclusion and future

present solutions

Today most protection and control/monitoring equipment in operation uses electromagnetic or electronic technologies. This equipment requires sufficiently powerful signals (≈ 5 to 50 VA) from current sensors which are often at a considerable distance (≈ 2 to 150 m).

In HV equipment, this power is supplied by conventional current transformers.

However, in HVA, several hundred digital protection and control/monitoring units are in operation. The majority, able to process signals with low energy levels, are associated with SS sensors. In HVB, experiments are currently underway with Faraday effect sensors using optical crystals or fibres.

Zero flux CTs are above all used in test bays and in DC transmission networks.

future solutions

The very fast evolution of protection and control/monitoring systems towards digital technologies has already resulted in major changes to sensor specifications. These specifications give priority to EMC, linearity and operating range of sensors.

■ EMC

Linked to the increasing use of electronic technologies. In this field, the optical sensor's behaviour is ideal.

■ linearity

Linear CTs (TPZ type) are generally space consuming (airgap present) and their linearity is not perfect. When a fault occurs, they transmit very high current leading to very high thermal stresses to the equipment connected to them. The SS sensor, with its perfect linearity, has the best performance here.

■ operating range

A CT has a very narrow operating range which limits its use to one single application. On the other hand, optical and SS sensors, with wider operating ranges (≈ 10 times) have greater possibilities of use, only limited by the equipment to which they are connected.

Optical and SS sensors thus give the best performances as regards the new technical constraints. A hybrid sensor, using a Rogowski coil as its sensing element and optical fibres as its transmission system, could prove the ideal solution.

In HVA, this solution is not yet feasible from an economic point of view.

However, the SS solution, through its cost and associated advantages, is the solution both for now and the future.

In HVB the use of these new sensors depends on the development of digital solutions for the protection and control/monitoring units and on the creation of digital interfaces for existing units. Sensor evolution will take off as soon as this equipment becomes available. This evolution has already begun and systems are already available, either «fully optical» or as in the ideal solution recommended above.

Consequently, conventional CTs, with their limited performances and relatively high costs, are doomed to vanish in the long term in HV, except perhaps those used for metering energy bills.

appendix 1: CT accuracy as in IEC 185

limits of errors for «measurement» secondaries

accuracy class	± Percentage current (ratio) error at percentage of rated current shown below				± phase displacement at percentage of rated current shown below							
					minutes				centiradians			
	5	20	100	120	5	20	100	120	5	20	100	120
0.1	0.4	0.2	0.1	0.1	15	8	5	5	0.45	0.24	0.15	0.15
0.2	0.75	0.35	0.2	0.2	30	15	10	10	0.9	0.45	0.3	0.3
0.5	1.5	0.75	0.5	0.5	90	45	30	30	2.7	1.35	0.9	0.9
1.0	3.0	1.5	1.0	1.0	180	90	60	60	5.4	2.7	1.8	1.8

Limits of error for «protective» secondaries

accuracy class	current error at rated primary current	phase displacement at rated primary current		composite error at rated accuracy limit primary current
	%	minutes	centiradians	%
5 P	± 1	± 60	± 1.8	5
10 P	± 3			10

appendix 2: CT classification as in IEC 44-6

The various classes of current transformers for protection, defined by IEC 44-6 according to their performances, are listed in the table opposite.

class	performances
P	Accuracy limit defined by the composite error ($\hat{\epsilon}_c$) with steady state symmetrical primary current. No limit for remanent flux.
TPS	Low leakage flux current transformer for which performance is defined by the secondary excitation characteristics and turns ratio error limits. No limit for remanent flux.
TPX	Accuracy limit defined by peak instantaneous error ($\hat{\epsilon}$) during specified transient duty cycle. No limit for remanent flux.
TPY	Accuracy limit defined by peak instantaneous error ($\hat{\epsilon}$) during specified transient duty cycle. Remanent flux not to exceed 10% of the saturation flux.
TPZ	Accuracy limit defined by peak instantaneous alternating current component error ($\hat{\epsilon}_{ac}$) during single energization with maximum d.c. offset at specified secondary loop time constant. No requirements for d.c. component error limit. Remanent flux to be practically negligible.

appendix 3: bibliography

[1] Techniques de l'ingénieur:
Transformateurs de mesure.
D 4720 12-1990, D 4722 12-1990,
D 4724 3-1991, R1016 10-1992.

[2] CEI 44-6 : First edition
1992-03 : Transformateurs de mesure.
Part 6 : Prescriptions concernant les
transformateurs de courant pour
protection pour la réponse en régime
transitoire.

[3] CEI 185 : Second edition 1987 and
its amendment 1 1990-07.
Transformateurs de courant.

[4] Méthode rapide de
prédétermination des transformateurs
de courant,
Pierre SCHUELLER (Merlin Gerin)
page 41 to 45, RGE n°4 avril 1990.

[5] Techniques de l'ingénieur:
Capteurs de courant à fibres
optiques.
R 1016 10-1992.

[6] La CEM: la compatibilité
électromagnétique,
Cahier Technique Merlin Gerin n° 149.
F. VAILLANT.

[7] Le transformateur de courant pour
la protection en HT,
Cahier Technique Merlin Gerin n° 164.
M. ORLHAC.