

# Industrial Linear Motors

Smart solutions are driven by

***LinMot***<sup>®</sup>



PRODUCT OVERVIEW

# Precision and dynamics

**In the products and in the everyday life of NTI AG, these values are inseparable.**

---

## NTI AG

NTI AG is a global manufacturer of high quality tubular style linear motors and linear motor systems and thus focuses on the development, production and distribution of linear direct drives for use in industrial environments.

Founded in 1993 as an independent business unit of the Sulzer Group, NTI AG has been in operation since 2000 as an independent company.

NTI AG headquarters are located in Spreitenbach, near Zurich in Switzerland. In addition to three production sites in Switzerland and Slovakia, NTI AG maintains a sales and support office LinMot® USA Inc. to cover the Americas.

The brands LinMot® for industrial linear motors and MagSpring® for magnetic springs are offered to customers worldwide. NTI AG maintains an experienced customer consultant sales and support network of over 80 locations worldwide.

For the realization of linear motion NTI AG is always a competent and reliable partner.



## Mission

LinMot offers its customers a sophisticated and dedicated linear drive system that can be easily integrated into all leading control systems. A high degree of standardization, delivery from stock and a worldwide distribution network insure the immediate availability and excellent customer support.

Our aim is to push linear direct drive technology and make it a standard machine design element. We offer highly efficient drive solutions that make a major contribution to the overall resource conservation effort.







# Linear Motors

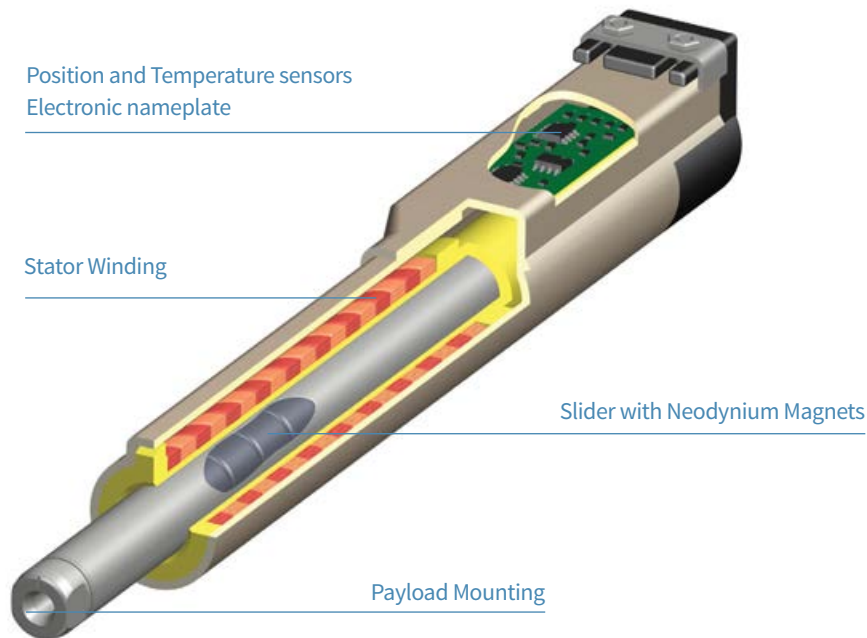

LinMot linear motors employ a direct electromagnetic principle. Electromagnetic force provides direct linear movement without the use of cams, gears, belts, or other mechanical devices. The engine consists of only two parts: The slider and the stator. The slider is made of neodymium magnets in a high precision stainless steel tube. In the stator are the motor windings, the bearing for the slider, the position detection and temperature sensors for thermal monitoring of the motor.

**Standard Motors**  
**High-Performance Motors**  
**Short Type Motors**  
**Stainless Steel Motors**  
**ATEX Motors**  
**Special Motors**

- ✓ Freely positionable
- ✓ Speed adjustable
- ✓ Acceleration adjustable
- ✓ Programmable force

- ✓ Extreme dynamics
- ✓ Monitored movements
- ✓ Soft movements
- ✓ Synchronized movements

- ✓ Long service life
- ✓ Low maintenance costs
- ✓ Hygienic
- ✓ Low energy costs



LinMot  
PS01-23x80-R  
SN: 1233.661.021  
PN: 0160-1233  
CE

LinMot  
PS01-23x80-R  
SN: 1233.661.019  
PN: 0160-1233  
CE

LinMot  
PS01-23x80-R  
SN: 1233.661.047  
PN: 0160-1233  
CE

LinMot  
PS01-23x80-R  
SN: 1233.661.042  
PN: 0160-1233  
CE

LinMot  
PS01-23x80-R  
SN: 1233.661.038  
PN: 0160-1233  
CE

## Standard Motors Universal

- » Highly dynamic drives
- » Wide stroke range
- » Available with cable outlet or with rotatable connector
- » Optional with air cooling
- » Wide range of applications in handling modules as well as in plant and machine construction

Stroke up to	mm	1830
Max. Force	N	23-1024
Nominal Force	N	9-354
Peak Velocity	m/s	6.9
Peak Acceleration	m/s <sup>2</sup>	500
Repeatability	mm	0.05/0.01
Stator Length	mm	162-410
Slider Length	mm	130-2000



## Short Type Motors Compact

- » Short design
- » Integrated mounting flange
- » Pluggable motor cable with cover
- » Free positionable cable outlet
- » For use where space is limited and in multi-axis applications

Stroke up to	mm	1480
Max. Force	N	29-255
Nominal Force	N	8-65
Peak Velocity	m/s	7.3
Peak Acceleration	m/s <sup>2</sup>	750
Repeatability	mm	0.05/0.01
Stator Length	mm	90/105/150
Slider Length	mm	130-1600



## HP Motors High-Performance

- » Particularly strong magnetic circuit
- » Increased duration of force and acceleration
- » Enables higher operating temperatures
- » In comparison with the standard motors, a smaller HP motor can be used with the same load.

Stroke up to	mm	1480
Max. Force	N	21-255
Nominal Force	N	15-92
Peak Velocity	m/s	7.3
Peak Acceleration	m/s <sup>2</sup>	780
Repeatability	mm	0.05/0.01
Stator Length	mm	162-257
Slider Length	mm	170-1600





**Stainless Steel Motors**  
*Hygienic*



- » Stainless steel housing  
EN 1.4404/ AISI 316
- » Hygienic design
- » Welded connections, no gaskets
- » Completely encapsulated (IP69K)
- » Optional integrated water cooling
- » For use in the food  
or in the pharmaceutical sector

Stroke up to	mm	980
Max. Force	N	210-888
Nominal Force	N	24-360
Peak Velocity	m/s	3.4
Peak Acceleration	m/s <sup>2</sup>	440
Repeatability	mm	0.05/0.01
Stator Length	mm	296/395/515
Slider Length	mm	395-1400

**P10-70 Motors**  
*Power packages*



- » 3 x 400VAC technology
- » Peak force up to 2700 N
- » Extremely high accelerations
- » Separate connector for sensor  
and power cable
- » Can be operated by standard  
“third party” Servo Drives

Stroke up to	mm	1770
Max. Force	N	557-2703
Nominal Force	N	65-862
Peak Velocity	m/s	7.4
Peak Acceleration	m/s <sup>2</sup>	975
Repeatability	mm	0.05/0.01
Stator Length	mm	180-500
Slider Length	mm	290-1990

**ATEX Motors**  
*Encapsulated*



- » Welded connections, no gaskets
- » Completely encapsulated (IP69K)
- » Optional integrated water cooling
- » Additional redundant temperature  
monitoring
- » For use in the zones 1/2 (gas)
- » Suitable for use in zones 21/22 (dust)

Stroke up to	mm	980
Max. Force	N	210-888
Nominal Force	N	24-360
Peak Velocity	m/s	3.4
Peak Acceleration	m/s <sup>2</sup>	440
Repeatability	mm	0.05/0.01
Stator Length	mm	296/395/515
Slider Length	mm	395-1400

## Special Motor Integrated Drive

### Motor drive module

- » High-Performance Linear Motor with integrated drive
- » Compact dimensions
- » High dynamics
- » Integrated mounting flange
- » Reduced wiring
- » Easy start-up
- » Low total cost



Preliminary		
Stroke up to	mm	1480
Max. Force	N	255
Nominal Force	N	35-65
Peak Velocity	m/s	3.9
Peak Acceleration	m/s <sup>2</sup>	350
Repeatability	mm	0.05/0.01
Stator Length	mm	150
Slider Length	mm	240-1600

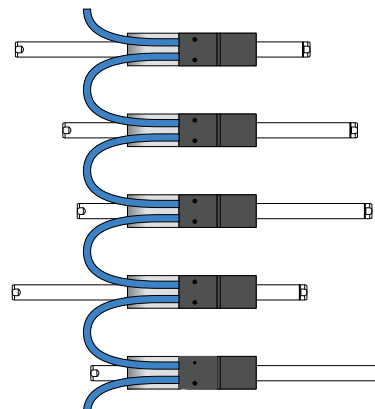

## Special Motor Integrated Drive IP69k

### Omega Motor

- » Stainless Steel Motor with integrated drive
- » Especially for applications in the pharmaceutical and food industry with very tight spaces
- » Welded connections
- » Completely encapsulated (IP69K)
- » Special designed connector
- » Control via fieldbus or Industrial Ethernet





**LinMot®**



# Linear Rotary Motors

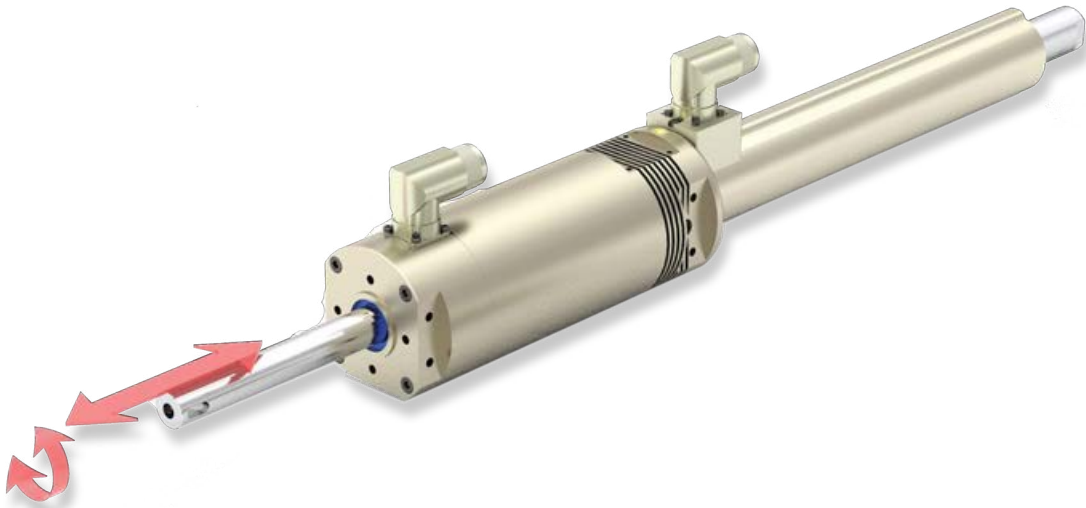

The PR01 motor series combines linear and rotary movements in a single integrated direct drive solution. The two motors are individually and independently driven. Working with a higher-level control high dynamic linear and rotary movements can be realized. These can be programmed either synchronously or independently of each other.

Complex tasks such as screwing, closing, capping, stacking, aligning and much more can be realized with a single component. The PR01 linear-rotary motor allows for independently specified linear force/pressing force as well as rotary torque.

**Standard**  
**Gearbox**  
**Hollow shaft**  
**Stainless steel**

✓ Linear and rotary direct drive

✓ Synchronous linear and rotary movements

✓ Programmable forces and torques

✓ Stainless steel version available

✓ With gear transmission or hollow shaft

✓ Simplest realization of seamers & cappers



**LinMot®**

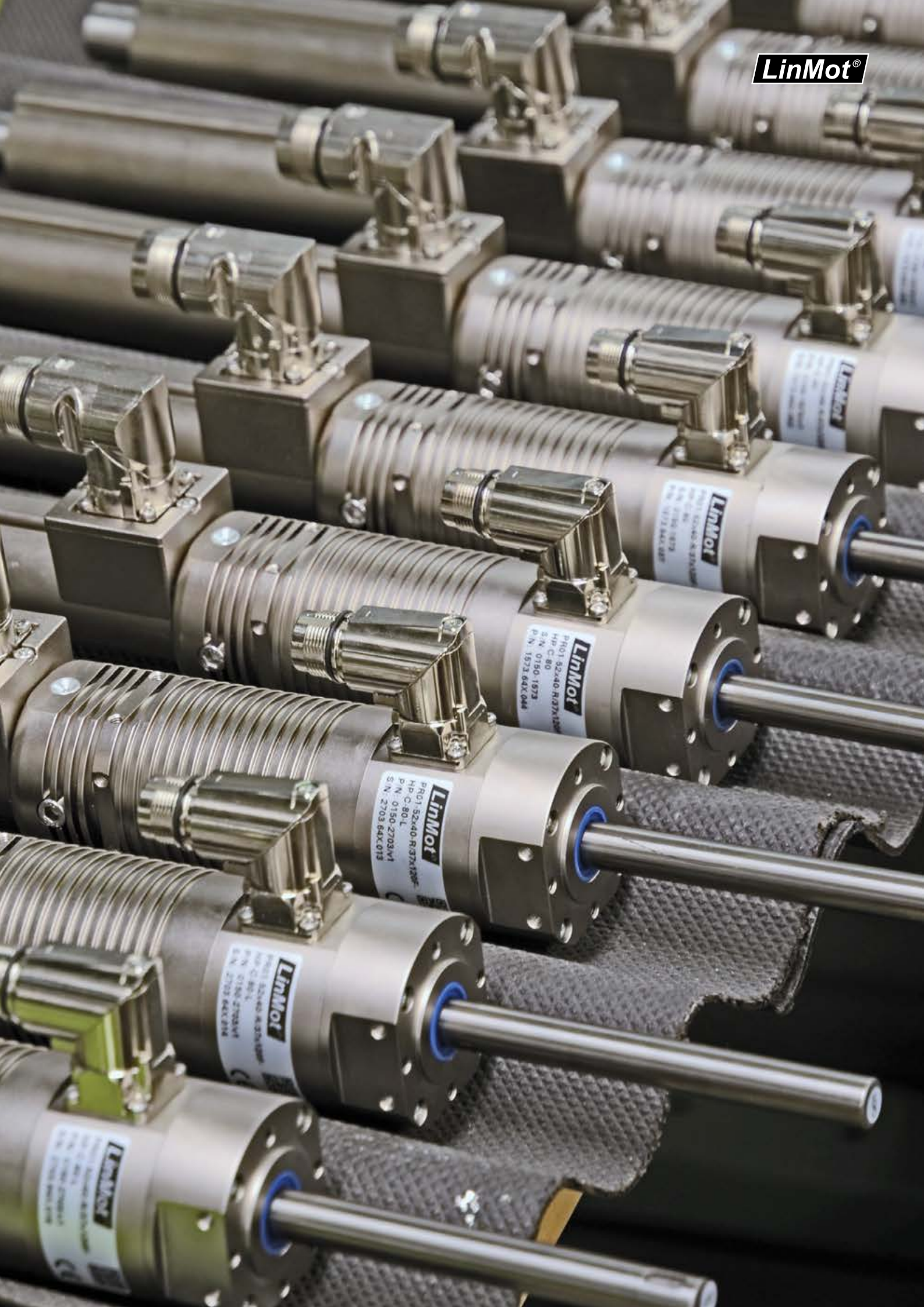

**LinMot**  
PR01-S2x40-R37x125  
HP C 80 L  
S/N 0150-2703M1  
P.N. 2703 64X 019

**LinMot**  
PR01-S2x40-R37x125  
HP C 80  
S/N 0150-1973  
P.N. 1573 64X 044

**LinMot**  
PR01-S2x40-R37x125  
HP C 80 L  
S/N 0150-2703M1  
P.N. 2703 64X 019

**LinMot**  
PR01-S2x40-R37x125  
HP C 80 L  
S/N 0150-2703M1  
P.N. 2703 64X 019



**Hollow shaft**



- » Version with hollow shaft
- » Inner diameter 2.5 / 4.0 mm
- » Upgradeable to vacuum gripper
- » Can be combined with a pneumatic or electric gripper

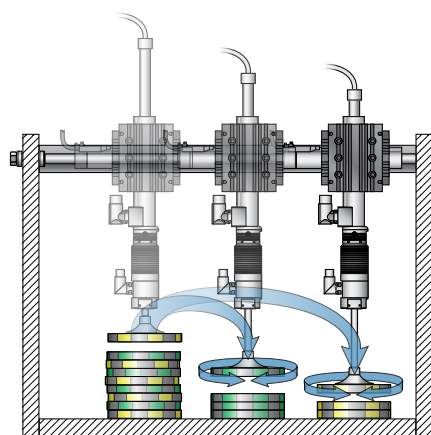

Stroke up to	mm	150
Max. Force	N	229-921
Nominal Force	N	45-319
Peak Velocity	m/s	3.9
Peak Torque	Nm	1.53-8.9
Constant Torque	Nm	0.32-2.64
Max. Num. of Rev.	rpm	1000-1500
Repeatability	mm	0.05/0.01
Length	mm	503-959

**Standard**



Stroke up to	mm	300
Max. Force	N	255-1024
Nominal Force	N	51-354
Peak Velocity	m/s	3.9
Peak Torque	Nm	1.53-8.9
Constant Torque	Nm	0.32-2.64
Max. Num. of Rev.	rpm	1000-1500
Repeatability	mm	0.05/0.01
Length	mm	503-1222

- » Linear direct drive
- » Rotary direct drive
- » Independent linear and rotary motions
- » Integrated position sensors
- » Absolute temperature feedback
- » Programmable position / motion profiles
- » Programmable press force
- » Programmable torque



**Stainless steel**

- » Linear rotary shaft in stainless steel  
EN 1.4404 / AISI 316
- » Hygienic Design
- » Resistant to cleaning supplies
- » Designed for use with food products
- » Designed for use in the  
chemical industry
- » With interchangeable plain bearings



**Gearbox**



- » Independent linear and rotary motions
- » For applications with high inertia loads
- » For applications with high torque requirement
- » 3 selectable transmission ratios
- » With guide rails to bear transverse loads

Max. Stroke	mm	150
Max. Force	N	1024
Nominal Force	N	354
Peak Velocity	m/s	3
Gear	n	1:5/1:7/1:10
Peak Torque	Nm	44/62/89
Constant Torque	Nm	9.5/13/19







# Linear Guides

LinMot linear guides are compact guide units with integrated ball bushings or bearings for the LinMot linear motors.

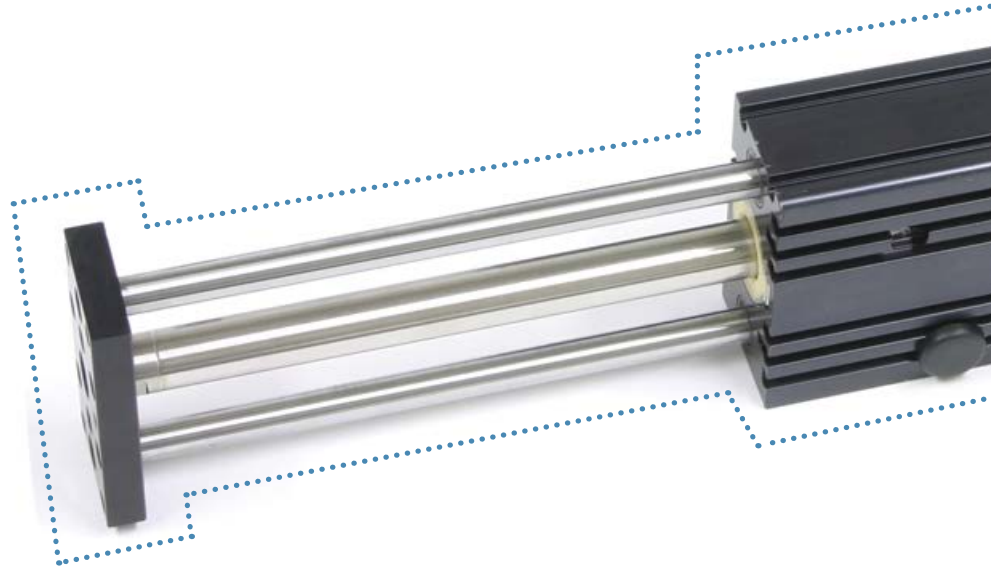
The guides use load bearings to support external forces, torques, and bending moments. Additionally the linear guides act as an anti-twist device. These products offer high guidance accuracy and facilitate dynamic and precise positioning of the load.

The load is connected directly to the front panel of the linear guide. The mechanical dimensions and mounting options are compatible with many pneumatic guides. The modular design allows an easy mounting of accessories, such as a mechanical brake or MagSpring (magnetic spring) for load balancing in a vertical installation position.



		
Linear Guides H01	Linear Guides B01	Linear Guides H10
<ul style="list-style-type: none"> <li>» Bearing external forces, torque and bending moments</li> <li>» Turning resistance</li> <li>» Compatible with pneumatic guides</li> <li>» Integrated Linear ball bearings or sintered bearings</li> </ul>	<ul style="list-style-type: none"> <li>» Increased stiffness by endplate</li> <li>» Use in high-clearance sliders</li> <li>» Bearing external forces, torque and bending moments</li> <li>» Turning resistance</li> <li>» Compatible with pneumatic guides</li> <li>» Integrated Linear ball bearings or sintered bearings</li> </ul>	<ul style="list-style-type: none"> <li>» Bearing external forces, torque and bending moments</li> <li>» Turning resistance</li> <li>» Compatible with pneumatic guides</li> <li>» Integrated Linear ball bearings or sintered bearings</li> </ul>



# MagSpring

## Weightlessness in your application

When installed vertically, linear motors and other direct drives must apply a constant force to counteract the force of gravity.

This is exactly why LinMot has developed the «Magnetic Spring» MagSpring.

Mounted parallel to the linear motor, the weight force can be passively compensated via the MagSpring. When the vertical axis de-energizes, the MagSpring may prevent lowering of the vertical axis. Utilizing a MagSpring the linear motor is used only for actual positioning and application of dynamic forces, thus allowing smaller dimensioned motors.

The functionality is based on the attraction of the permanent magnet. Accordingly, no power supply (electricity, compressed air, etc.) is necessary, allowing easy implementation of safety-related applications.



Thanks to the constant power path characteristic numerous applications are possible, such as position-independent generation of a constant contact force, the application of a constant holding force over a large stroke range or the unilateral power assistance in driving tasks.

**MagSpring®**

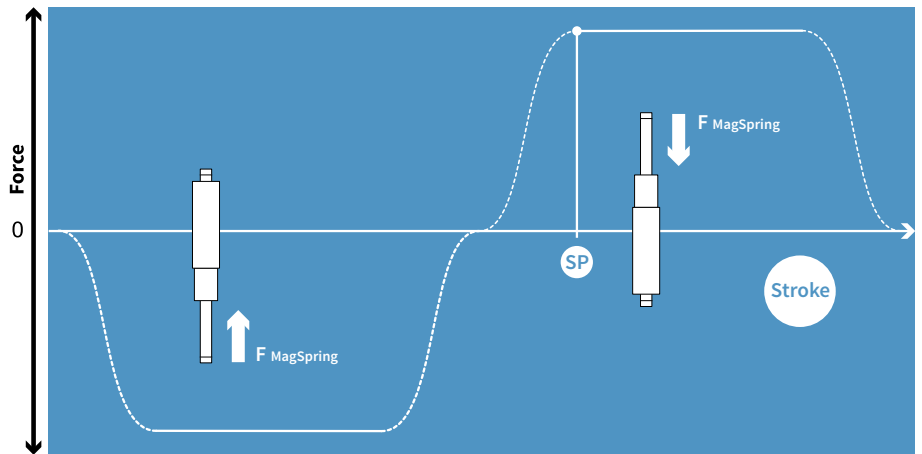

**Mechanical Spring**

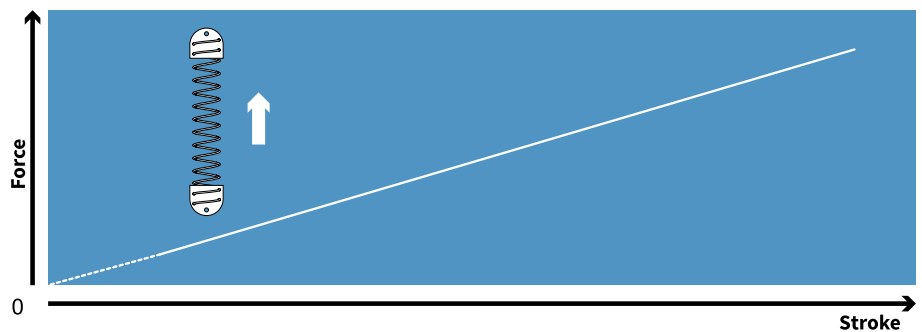

M01-20			M01-37		
Constant force	N	11 / 17 / 22	Constant force	N	40 / 50 / 60
Stroke (Constant force)	mm	≤ 290	Stroke (Constant force)	mm	≤ 275
Stator mass	g	75 - 388	Stator mass	g	440 - 1800
Slider mass	g	75 - 280	Slider mass	g	75 - 280

**Product characteristics**

- » Constant force along the entire stroke
- » Purely passive, no electricity needed nor compressed air
- » Ideal for compensating the gravitational force
- » Also suitable for dynamic movements
- » Different stroke ranges and forces
- » Compatible with H-guides
- » Simple construction



# Motor accessories

Plenty of choice for customized applications

---

## Electric



- » **Motor cable**  
For stationary operation or cable tracks and robot applications



- » **Connection cable and converter**  
PC configuration cable and interface cable



- » **External position sensor**  
For high precision applications in the micron range and / or absolute Position detection



- » **Control Box**  
For quick setup of Servo Drives



- » **Power Supplies**  
In the power range of 300 W, 500 W, 1000 W



- » **Transformer Supplies**  
In the power range of 420 VA / 900 VA / 1500 VA

---

## Mechanically



- » **Mounting Flanges**  
Fast motor assembly and optimal cooling



- » **Slider Mounting**  
Prevents misalignment



- » **Brake**  
Holds the load in a vertical mounting position even in off position



**LinMot®**

# System integration

LinMot products fit every control concept

**SIEMENS**

**Rockwell Automation**  
Allen-Bradley

**BECKHOFF**



**Schneider Electric**

**BOSCH**

Controller



**PROFI BUS**

**PROFI NET**

**DeviceNet**

**EtherNet/IP**

**CANopen**

Communication Interfaces



24...72 VDC

LinMot Drives





OMRON

Lenze

CODESYS

NATIONAL INSTRUMENTS  
LabVIEW™

MATLAB®  
SIMULINK™



ETHERNET  
POWERLINK

EtherCAT™

sercos  
the automation bus

RS 485

RS 232



3 x 400 VAC

LinMot Drives



3rd Party Drives



P10-70



AC Servo



P10-70



AC Servo

# Servo Drives

The wide product range of LinMot servo drives allows the rapid implementation in applications from simple two position point to point movements up to complex, high-precision multi-axis synchronization with electronic line shaft.

LinMot Drives cover the entire power range from the 24 to 72VDC low voltage range up to powering high performance servo motors with direct connection to 3phase 480VAC.

**E 1200**

**E 1100**

**B 1100**

**C 1200**

**C 1100**

**A 1100**

**E 1400**

**M 8050**

✓ Wide range of applications from point to point to complex multi-axis applications

✓ Serial communication, field buses and realtime ETHERNET

✓ Internally stored motion profiles or program sequences

✓ Control of position, velocity, acceleration and force

✓ Integrated safety functions for switching off the power output stage

✓ Compact design and easy commissioning



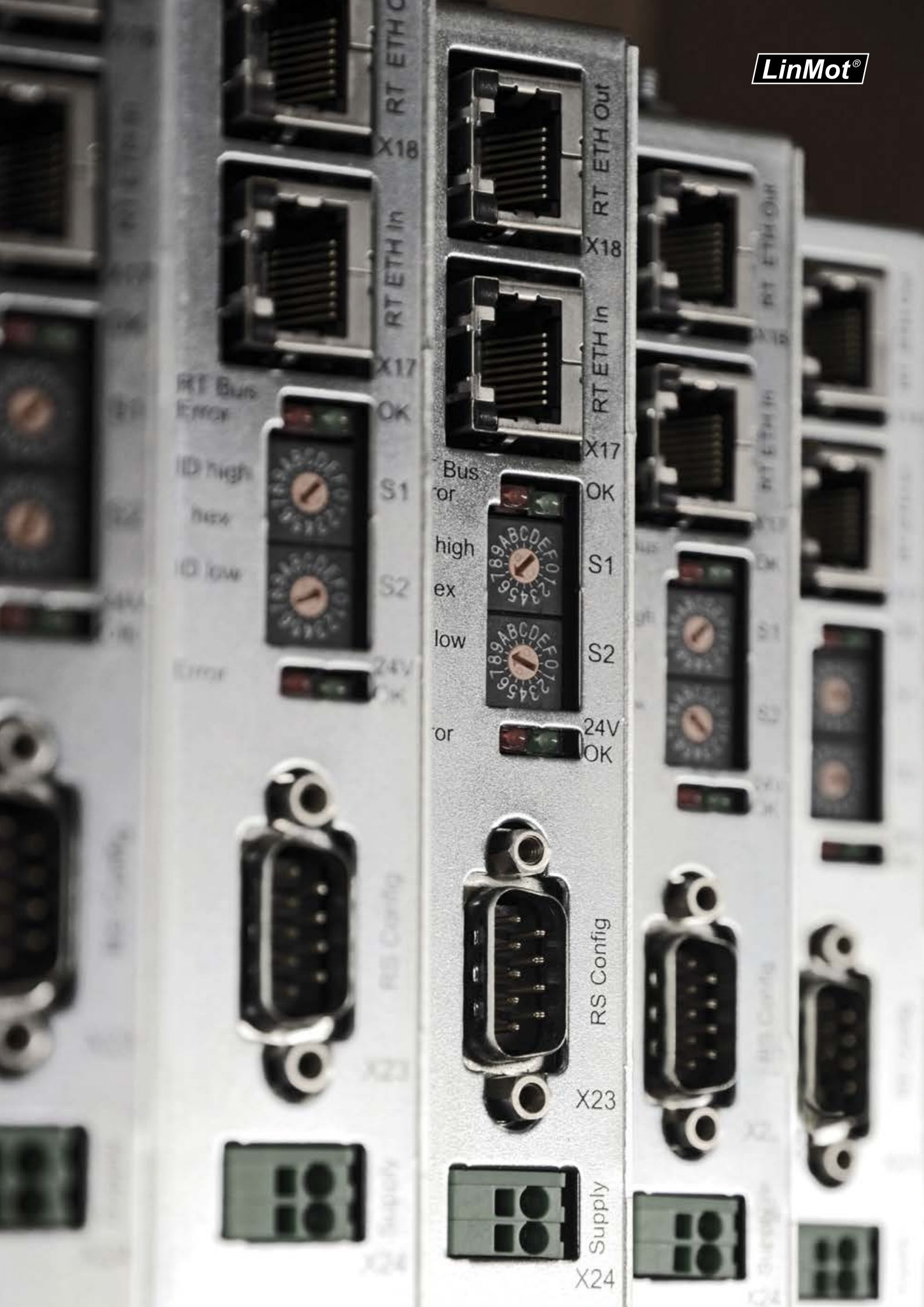

RT Bus  
Error

ID high  
new

ID low

Error

RT ETH Out  
X18

RT ETH In  
X17

OK

S1

S2

24V  
OK

RS Config  
X23

Supply  
X24

Bus  
or  
high  
ex  
low

or

RT ETH Out  
X18

RT ETH In  
X17

OK

S1

S2

24V  
OK

RS Config  
X23

Supply  
X24

Bus  
or  
high  
ex  
low

or

RT ETH Out  
X18

RT ETH In  
X17

OK

S1

S2

24V  
OK

RS Config  
X23

Supply  
X24

## C 1200

Compact Drive / NC Motion



- » Absolute / relative positioning commands
- » Limited jerk motion commands
- » Time Curves
- » Real Time (Streaming)
- » Synchronous control (Drive profiles)
- » PLC or Stand-Alone Solutions
- » Digital and Analog IO's
- » Safe Torque Off
- » Safe Limited Speed Ready
- » Interface for optional incremental and absolute sensor
- » Supports Plug and Play
- » UL 508C

## C 1100

Compact-Drive / Point to Point



- » Absolute / relative positioning commands
- » Limited jerk motion commands
- » Time Curves
- » Real Time (Streaming)
- » PLC or Stand-Alone Solutions
- » Digital and Analog IO's
- » Safe Torque Off
- » Safe Limited Speed Ready
- » Interface for optional incremental and absolute sensor
- » Supports Plug and Play
- » UL 508C



## A 1100

Small drive for instrument engineering



- » Absolute / relative positioning commands
- » Limited jerk motion commands
- » Time Curves
- » PLC or Stand-Alone Solutions
- » Digital IO's
- » Supports Plug and Play
- » UL 508C



**E 1100**  
Universal



- » Absolute / relative positioning commands
- » Limited jerk motion commands
- » Time Curves
- » Real Time (Streaming)
- » Master Encoder Synchronization (In/Out)
- » PLC or Stand-Alone Solutions
- » Digital and Analog IO's
- » Interface for optional incremental sensor
- » Master / Slave Solutions
- » UL 508C



**E 1200**  
High End



- » Absolute / relative positioning commands
- » Limited jerk motion commands
- » Time Curves
- » Real Time (Streaming)
- » Synchronous control (Drive profiles)
- » Master Encoder Synchronization (In/Out)
- » PLC or Stand-Alone Solutions
- » Industrial Ethernet Configuration / Remote Access Ethernet
- » Digital and Analog IO's
- » Safe Torque Off
- » Interface for optional incremental and absolute sensor
- » Position Encoder Simulation (RS 422)
- » Master / Slave Solutions
- » ± 10 VDC Force / Speed Control
- » Supports Plug and Play

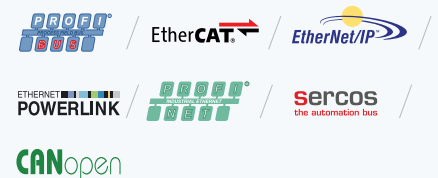

**B 1100**  
Standard



- » Absolute / relative positioning commands
- » Limited jerk motion commands
- » PLC or Stand-Alone Solutions
- » Digital und Analog IO's
- » Interface for optional incremental sensor
- » Position Encoder Simulation (RS 422)
- » ± 10 VDC Force / Speed Control





## E 1400

High feature drive



- » Controls LinMot motors / AC servomotors
- » Absolute / relative positioning commands
- » Limited jerk motion commands
- » Time Curves
- » Real Time (Streaming)
- » Synchronous control (Drive profiles)
- » Master Encoder Synchronization (In/Out)
- » PLC or Stand-Alone Solutions
- » Industrial Ethernet Configuration / Remote Access Ethernet
- » Digital and Analog IO's
- » Safe Torque Off
- » Safe Limited Speed Ready
- » Interface for optional incremental and absolute sensor
- » Position Encoder Simulation (RS 422)
- » Master / Slave Solutions
- » ± 10 VDC Force / Speed Control
- » Supports Plug and Play



## M 8050

Modular drive concept



- » Compact design up to 8 axis
- » Central supply module
- » SafeTorque Off
- » Safe Limited Speed Ready
- » Modular, wired through backplane
- » Push-Pull motor connectors
- » Easy and fast installation





LinMot  
Type: ...  
Part No.: ...  
Serial No.: ...  
Hardware: ...  
Signal Supp.: ...  
Power Supp.: ...  
<http://www.linmot.com>

LinMot  
PN: 0150-2034  
SN: 2034.5H2.008  
Ver. 1 Rev. E  
MB1150-ML-XC-1S-H

LinMot  
PN: 0150-2034  
SN: 2034.5H2.009  
Ver. 1 Rev. E  
MB1150-ML-XC-1S-H

LinMot  
PN: 0150-2034  
SN: 2034.5H2.004  
Ver. 1 Rev. E  
MB1150-ML-XC-1S-H

# LinMot Talk and LinMot Designer

**Correctly size and monitor your linear motors**

## **Complete control in configuration and operating modes**

A linear drive application starts with the correct sizing of the linear motor. LinMot provides designers with an easy to use tool. LinMot Designer calculates the parameters required to select a drive and linear motor for a given motion sequence and load case, and relates them to the selected linear motor and servo drive.

Using LinMot Talk PC interface, the engineer can configure LinMot servo drives. The motors are also monitored during operation and the current motion sequences are analysed (monitoring).

The integrated control panel gives the user direct access to the control and status words, as well as all commands that are invoked by the upper-level controller.

## **Design with LinMot Designer**

- » Specification of all global data
- » Simulation of motions
- » Determination of kinematic data
- » Calculating motor power draw
- » Approval of selected motor
- » “Cost efficiency” tab that compares energy use between pneumatic cylinders and linear motors
- » Design of rotary motors

## **Configuration with LinMot Talk**

- » Drive and motor configuration
- » Configuration of application data
- » Create and save motion sequences
- » Controller optimization and status monitoring
- » Records and measurements with oscilloscope
- » Reading error history (error management)



# Commissioning by a click

**Proven technology to get moving quickly.**

## Configuration via PnP

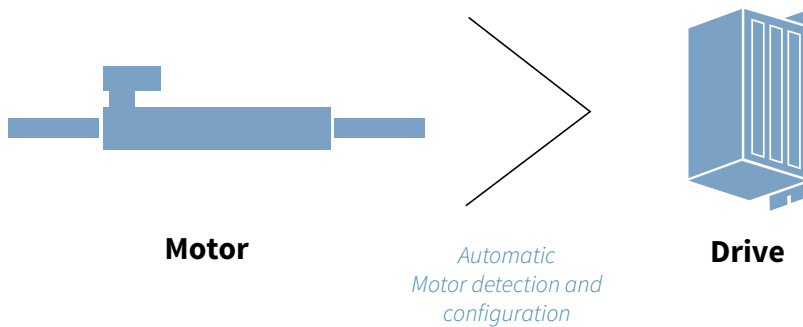

## SPS Libraries and Programming Examples

LinMot Drives have all common fieldbus interfaces available for connection to a master controller.

In order to realize simple control concept integration, extensive function blocks and programming examples are provided for the customer. These function blocks allow for direct and quick LinMot drive integration.

The function blocks run standard functions as well as commands such as drive parameterization and configuration directly from the controller. The complete drive configuration of the corresponding axis is thus stored on the controller.

Maintenance or replacement can be easily realized via automatic drives detection and configuration over the communication bus. Thus manual and time-consuming configuration of the drives in case of failure is eliminated.

## Configuration via PLC

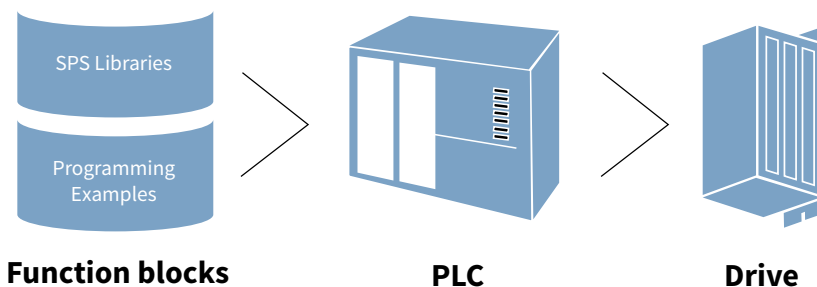

### Automatic motor configuration

Plug & Play technology, well established in the computer industry, is now used by LinMot for commissioning linear motors.

With Plug & Play motors, the parameters are saved directly to the stator. The servo drive reads these values when it boots up, and sets the parameters accordingly. This automatic device detection

eliminates the selection of the required model parameters from an extensive library.

Immediately after installing and connecting the cable, the motor can be moved immediately. Without having the configuration software to boot, first commands can be sent directly by the PLC control. Initial commissioning and replacement with a motor are thus very simple operations.

# LinMot Fields of Application

**The right linear motor for every application**

LinMot linear motors and servo drives are built for use in harsh, demanding industrial environments. Their exceptional technical properties, low-maintenance operation, and extremely long life set them apart.

Within the wide product range, LinMot offers electrical products for complex servo applications and simple pneumatic replacement. LinMot technology has been proven for years to be the ideal solution in many fields.



**Packaging**



**Medical & Pharmaceutical**



**Food**



**Automotive**



**Beverage**



**Packaging & Labelling**



**Laboratory Automation**



**Textile Machines**



**Wood Machines**

What has been achieved in the past by pneumatic cylinders, servo motors or mechanical cams, is now increasingly implemented directly by linear motors.

The fields of application are many:

- » Pick & Place
- » Flying Cut-Off
- » Synchronous insertion
- » Fill level metering
- » Blister filling
- » Pallet filling
- » Bottle and tube filling
- » Sealer control
- » Printing Registration
- » Pad printing
- » Doctor blade controls
- » Label positioning
- » Label application
- » Camera positioning
- » Lighting positioning and many more

LinMot®

LinMot® RS01.52x40-R  
Rotative Part  
S/N:1572 5T1.043

CE





---

Electric linear motion  
Superior to pneumatic cylinders in  
many applications.

# Electricity instead of air

**Energy and cost savings - Unique Advantages of electric linear motion technology**

---

Machine design engineers have found numerous situations where linear direct drives provide distinct advantages over pneumatic actuators. These include: If more than two end positions are needed, if the positions are to be changed by software, if running synchronously with a main drive is required or the dynamics / life of a pneumatic cylinder is simply no longer sufficient.

Due to the high operating costs of pneumatic cylinders, linear motors may also prove to be a cost efficient alternative in simple point to point motions even with only two end positions.

This is especially true when the motions are in a cyclic operation and carried out regularly. Many times pneumatic cylinders must be oversized due to the speed and load conditions. In many cases the pneumatic cylinder energy and maintenance costs exceed the investment costs within a few weeks.

A typical cost comparison shows the impressive cost savings with LinMot linear motors.

**Cost comparison example**

**Application**

**30 cycles per minute  
with 500 ms travel time  
and 500 ms pause time**

**15 kg**      **15 kg**

100    200    300    400

Extend	➡	500 ms
Stop	▬	500 ms
Retract	⬅	500 ms
Stop	▬	500 ms
<b>Total cycle time</b>		<b>2000 ms</b>

**Parameter**

Stroke:	400 mm
Positioning time:	500 ms
Required acceleration:	10 m/s <sup>2</sup>
Required speed:	1 m/s
Expected period of operation:	8000 h

**Comparison of technology**

**Linear Motors**

- » Acceleration work is performed only during 100 ms.
- » At standstill, no energy is expended.
- » At a constant speed, only energy to overcome the friction is used.
- » Kinetic energy is stored in the DC link capacitor of the servo drives.
- » **The measured power consumption for this application is 92 W on average.**

**Pneumatic cylinder**

- » For the required mass and velocity a piston diameter of 50 mm is required.
- » During the entire moving time, compressed air power is required.
- » Dampers absorb the energy during braking. The energy cannot be stored.
- » Due to the cylinder diameter, the stroke and the cycle time the annual air requirement equals 150.000 Nm<sup>3</sup> per year.
- » Pneumatic manufacturers list production costs for compressed air at 0.025 EUR/Nm<sup>3</sup>.

**Energy costs**

- » At a current price of 0.12 € / kWh and 8000 hours of operation, **the annual energy cost is € 96.**
- » With production costs of 0.025 EUR / Nm<sup>3</sup> and an air consumption of 150.000 Nm<sup>3</sup>.
- » The annual compressed air costs are 3.750.- €.**

# Total cost comparison and CO<sub>2</sub> emissions

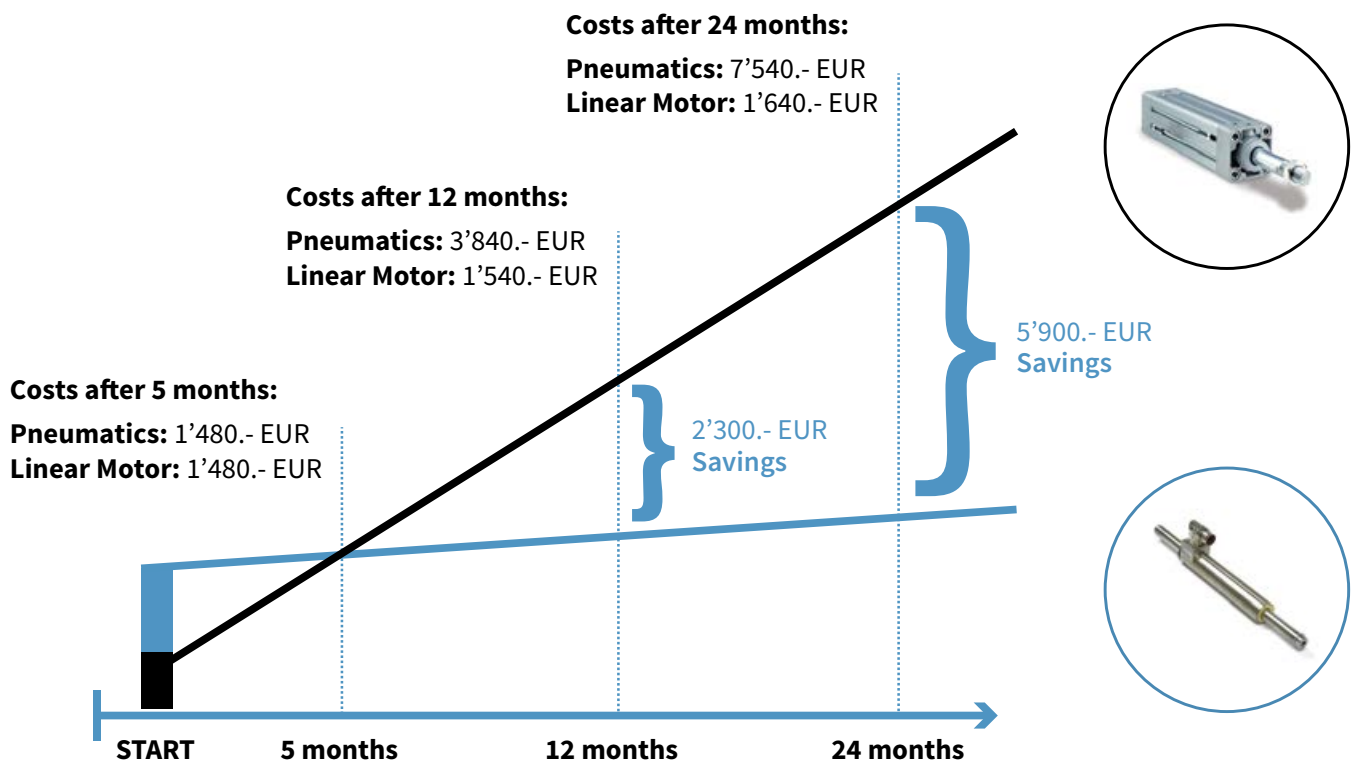

The initial costs of a linear direct drive system including all components (cables, converters, etc.) required for the operation are higher than the initial costs for a pneumatic actuator system (incl. valves, hoses, etc.). But by accounting for the significantly lower energy costs of linear motors, these initial costs are recovered in less than half a year. After this time, the cost savings are realized as lower operating costs and increased profit margins. The operating energy costs of pneumatics exceed their initial investment costs after only three months.

CO<sub>2</sub> emissions can be drastically reduced by switching to an electric linear drive providing another huge benefit. The energy of 24.000 kWh, which is additionally required by the pneumatic cylinder in this sample calculation, results in an annual output of 12.000 kg CO<sub>2</sub>. This calculation takes into account the German energy mix of 500g CO<sub>2</sub> / kWh.

Thus, the CO<sub>2</sub> record speaks clearly: A change to electric direct drives!





# Competence

Everything from one source



---

## Support

As the world's leading manufacturer of industrial linear motors, NTI AG uses its knowledge and innovation to provide customized solutions. Seeking the optimal solution of specific drive tasks our application engineers offer exceptional support to the customer. Our customers can rely on years of production experience for the implementation and production for customer specific drive solutions.



---

## Innovation

Through continuous development and investment and with the input of our worldwide sales consultants, engineers and partners NTI AG is able to offer its customers commercially viable new products at attractive prices.



---

## Production

The standardized LinMot and MagSpring products are manufactured via self-designed production facilities. This guarantees rapid product availability even in larger quantities while simultaneously allowing for maximum flexibility and customizations. The highly automated production facilities ensure constant high quality products.



**Seeking optimal solutions for specific drive tasks LinMot application engineers provide exceptional customer support.**



---

## Logistics

LinMot and MagSpring products are standardized products, which are typically supplied from stock and available worldwide. Currently more than 1000 different drive and motor combinations are in stock and available within 48 hours worldwide.



---

## Quality

Quality control starts with the checking of incoming material and continues into production all the way through the final burn-in testing before delivery. All LinMot linear motors are subjected to a 24-hour burn-in before delivery. For long-term quality assurance, LinMot products are labeled with a unique serial number on the Stator, on its electronic nameplate and in the Servo Drive.



# ALL LINEAR MOTION FROM A SINGLE SOURCE

## LinMot Europe

NTI AG - LinMot & MagSpring  
Haerdlistrasse 15  
CH-8957 Spreitenbach  
Switzerland

☎ +41 (0)56 419 91 91  
🖨 +41 (0)56 419 91 92

✉ office@linmot.com  
🏠 www.linmot.com

## LinMot USA

LinMot USA, Inc.  
204 E Morrissey Dr.  
Elkhorn, WI 53121  
United States

☎ 877-546-3270  
🖨 800-463-8708

✉ usasales@linmot.com  
🏠 www.linmot-usa.com

**LinMot®**

